

# **Recommended Practice for Design and Installation of Offshore Production Platform Piping Systems**

API RECOMMENDED PRACTICE 14E (RP 14E)  
FIFTH EDITION, OCTOBER 1, 1991

**American Petroleum Institute**  
1220 L Street, Northwest  
Washington, DC 20005



**Issued by**  
**AMERICAN PETROLEUM INSTITUTE**  
**Production Department**

FOR INFORMATION CONCERNING TECHNICAL CONTENTS OF  
THIS PUBLICATION CONTACT THE API PRODUCTION DEPARTMENT,  
1201 MAIN STREET, SUITE 2535, DALLAS, TX 75202-3904 — (214) 748-3841.  
SEE BACK COVER FOR INFORMATION CONCERNING HOW TO OBTAIN  
ADDITIONAL COPIES OF THIS PUBLICATION.

Users of this publication should become completely familiar with its scope  
and content. This publication is intended to supplement rather  
than replace individual engineering judgment.

OFFICIAL PUBLICATION



REG. U.S. PATENT OFFICE

Copyright © 1991 American Petroleum Institute

**API RECOMMENDED PRACTICE FOR DESIGN AND INSTALLATION  
OF OFFSHORE PRODUCTION PLATFORM PIPING SYSTEMS**

**TABLE OF CONTENTS**

	Page
<b>POLICY</b> .....	6
<b>FOREWORD</b> .....	7
<b>DEFINITIONS</b> .....	7
<b>SYMBOLS</b> .....	8
<b>SECTION 1 — GENERAL</b> .....	9
Scope .....	9
Code for Pressure Piping .....	9
Policy .....	9
Industry Codes, Guides and Standards .....	9
American Iron and Steel Institute .....	9
American National Standards Institute .....	9
American Petroleum Institute .....	10
American Society for Testing and Materials .....	10
American Society of Mechanical Engineers .....	10
National Association of Corrosion Engineers .....	10
National Fire Protection Association .....	10
Gas Processors Suppliers Association .....	10
Hydraulics Institute .....	10
Governmental Rules and Regulations .....	10
Demarcation Between Systems with Different Pressure Ratings .....	11
Corrosion Considerations .....	13
General .....	13
Weight Loss Corrosion .....	13
Sulfide Stress Cracking .....	13
Chloride Stress Cracking .....	13
Application of NACE MR-01-75 .....	13
<b>SECTION 2 — PIPING DESIGN</b> .....	14
Pipe Grades .....	14
Non-Corrosive Hydrocarbon Service .....	14
Corrosive Hydrocarbon Service .....	14
Sulfide Stress Cracking Service .....	14
Utilities Service .....	14
Tubing .....	14
Sizing Criteria — General .....	14
Sizing Criteria for Liquid Lines .....	15
General .....	15
Pump Piping .....	15
Sizing Criteria for Single-Phase Gas Lines .....	21
General Pressure Drop Equation .....	21
Empirical Pressure Drop .....	21
Gas Velocity Equation .....	22
Compressor Piping .....	23
General Notes .....	23
Sizing Criteria for Gas/Liquid Two-Phase Lines .....	23
Erosional Velocity .....	23
Minimum Velocity .....	23
Pressure Drop .....	23
Pipe Wall Thicknesses .....	25
Joint Connections .....	25
Expansion and Flexibility .....	25
Start-Up Provisions .....	25
References .....	26

## TABLE OF CONTENTS (Continued)

	Page
<b>SECTION 3 — SELECTION OF VALVES</b>	<b>29</b>
General	29
Types of Valves	29
Ball Valves	29
Gate Valves	29
Plug Valves	29
Butterfly Valves	29
Globe Valves	29
Diaphragm (Bladder) Valves	29
Needle Valves	30
Check Valves	30
Valve Sizing	30
Valve Pressure and Temperature Ratings	30
Valve Materials	31
Non-Corrosive Service	31
Corrosive Service	31
Chloride Stress Cracking Service	31
Sulfide Stress Cracking Service	31
References	31
<b>SECTION 4 — FITTINGS AND FLANGES</b>	<b>32</b>
General	32
Welded Fittings	32
Screwed Fittings	32
Branch Connections	32
Flanges	32
General	32
Gaskets	33
Flange Protectors	34
Bolts and Nuts	34
Proprietary Connectors	34
Special Requirements for Sulfide Stress Cracking Service	34
Erosion Prevention	34
References	34
<b>SECTION 5 — DESIGN CONSIDERATIONS FOR PARTICULAR PIPING SYSTEMS</b>	<b>35</b>
General	35
Wellhead Accessory Items	35
Sampling and Injection Connections	35
Chokes	35
Flowline and Flowline Accessories	35
Flowline Pressure Sensor	35
Flowline Orifice Fitting	35
Flowline Heat Exchanger	35
Flowline Check Valve	35
Flowline Support	35

## TABLE OF CONTENTS (Continued)

	Page
<b>SECTION 5 (continued)</b>	
Production Manifolds .....	35
General .....	35
Manifold Branch Connections .....	35
Manifold Valve Installation .....	35
Process Vessel Piping .....	35
Utility Systems .....	38
Pneumatic Systems .....	38
Air Systems .....	38
Gas Systems .....	38
Fire Water Systems .....	38
Potable Water Systems .....	38
Sewage Systems .....	38
Heating Fluid and Glycol Systems .....	38
Pressure Relief and Disposal Systems .....	40
General .....	40
Relief Device Piping .....	40
Relief (Disposal) System Piping .....	40
Drain Systems .....	40
Pressure Drains .....	41
Gravity Drains .....	41
Bridge Piping Between Platforms .....	41
Risers .....	41
Sampling Valves .....	41
References .....	41
<b>SECTION 6 — CONSIDERATIONS OF RELATED ITEMS .....</b>	
General .....	42
Layout .....	42
Elevations .....	42
Piping Supports .....	42
Other Corrosion Considerations .....	42
Protective Coatings for External Surfaces .....	42
Types of Platform Piping Coating Systems .....	42
Selection of Platform Piping Coating Systems .....	42
Risers .....	42
Corrosion Protection for Internal Surfaces .....	42
Process Piping .....	42
Water Piping .....	42
Protective Coatings .....	42
Compatibility of Materials .....	42
Non-Destructive Erosion and/or Corrosion Surveys .....	43
Cathodic Protection .....	43
Thermal Insulation .....	43
Noise .....	43
Pipe, Valves and Fittings Tables .....	43
Inspection, Maintenance & Repair .....	43

## TABLE OF CONTENTS (Continued)

	Page
<b>SECTION 7 — INSTALLATION AND QUALITY CONTROL</b> .....	45
General .....	45
Authorized Inspector .....	45
Welding .....	45
Safety Precautions.....	45
Welding Procedure Qualification.....	45
Welder Qualification.....	45
Welding Records.....	45
Welding Requirements .....	45
Heat Treatment.....	45
Examination and Inspection.....	45
Radiographic Inspection.....	45
Pressure Testing.....	45
Hydrostatic Tests.....	45
Pneumatic Tests.....	45
Test Record.....	46
<b>APPENDIX A — EXAMPLE PROBLEMS</b> .....	47
Introduction .....	47
Flowline Piping Design.....	47
Pump Suction Piping Design.....	50
<b>APPENDIX B — ACCEPTABLE BUTT WELDED JOINT DESIGN FOR UNEQUAL WALL THICKNESSES</b> .....	52
<b>APPENDIX C — EXAMPLE PIPE, VALVES AND FITTINGS TABLES</b> .....	54
<b>APPENDIX D — LIST OF EQUATIONS</b> .....	57
<b>APPENDIX E — LIST OF FIGURES</b> .....	58
<b>APPENDIX F — LIST OF TABLES</b> .....	59

**Attention Users of this Publication:** Portions of this publication have been changed from the previous edition. The locations of changes have been marked with a bar in the margin, as shown to the left of this paragraph. In some cases the changes are significant, while in other cases the changes reflect minor editorial adjustments. The bar notations in the margins are provided as an aid to users as to those parts of this publication that have been changed from the previous edition, but API makes no warranty as to the accuracy of such bar notations.

*NOTE: This is the fifth edition of this Recommended Practice. It includes changes to the fourth edition adopted at the 1990 Standardization Conference.*

*This standard shall become effective on the date printed on the cover, but may be used voluntarily from the date of distribution.*

*Requests for permission to reproduce or translate all or any part of the material published herein should be addressed to the Director, American Petroleum Institute Production Department, 2535 One Main Place, Dallas TX 75202-8904.*

## POLICY STATEMENT

API PUBLICATIONS NECESSARILY ADDRESS PROBLEMS OF A GENERAL NATURE. WITH RESPECT TO PARTICULAR CIRCUMSTANCES, LOCAL, STATE, AND FEDERAL LAWS AND REGULATIONS SHOULD BE REVIEWED.

API IS NOT UNDERTAKING TO MEET DUTIES OF EMPLOYERS, MANUFACTURERS, OR SUPPLIERS TO WARN AND PROPERLY TRAIN AND EQUIP THEIR EMPLOYEES, AND OTHERS EXPOSED, CONCERNING HEALTH AND SAFETY RISKS AND PRECAUTIONS, NOR UNDERTAKING THEIR OBLIGATIONS UNDER LOCAL, STATE, OR FEDERAL LAWS.

NOTHING CONTAINED IN ANY API PUBLICATION IS TO BE CONSTRUED AS GRANTING ANY RIGHT, BY IMPLICATION OR OTHERWISE, FOR THE MANUFACTURE, SALE, OR USE OF ANY METHOD, APPARATUS, OR PRODUCT COVERED BY LETTERS PATENT. NEITHER SHOULD ANYTHING CONTAINED IN THIS PUBLICATION BE CONSTRUED AS INSURING ANYONE AGAINST LIABILITY FOR INFRINGEMENT OF LETTERS PATENT.

GENERALLY, API STANDARDS ARE REVIEWED AND REVISED, REAFFIRMED, OR WITHDRAWN AT LEAST EVERY FIVE YEARS. SOMETIMES A ONE-TIME EXTENSION OF UP TO TWO YEARS WILL BE ADDED TO THIS REVIEW CYCLE. THIS PUBLICATION WILL NO LONGER BE IN EFFECT FIVE YEARS AFTER ITS PUBLICATION DATE AS AN OPERATIVE API STANDARD OR, WHERE

AN EXTENSION HAS BEEN GRANTED, UPON REPUBLICATION. STATUS OF THIS PUBLICATION CAN BE ASCERTAINED FROM THE API AUTHORIZING DEPARTMENT (TEL. 214-748-3841). A CATALOG OF API PUBLICATIONS AND MATERIALS IS PUBLISHED ANNUALLY AND UPDATED QUARTERLY BY API, 1220 L ST., N.W., WASHINGTON, D.C. 20005.

American Petroleum Institute (API) Recommended Practices are published to facilitate the board availability of proven, sound engineering and operating practices. These Recommended Practices are not intended to obviate the need for applying sound judgment as to when and where these Recommended Practices should be utilized.

The formulation and publication of API Recommended Practices is not intended to, in any way, inhibit anyone from using any other practices.

Any Recommended Practice may be used by anyone desiring to do so, and a diligent effort has been made by API to assure the accuracy and reliability of the data contained herein. However, the Institute makes no representation, warranty or guarantee in connection with the publication of any Recommended Practice and hereby expressly disclaims any liability or responsibility for loss or damage resulting from its use, for any violation of any federal, state or municipal regulation with which an API recommendation may conflict, or for the infringement of any patent resulting from the use of this publication.

**FOREWORD**

- a. This recommended practice (RP) is under the jurisdiction of the American Petroleum Institute (API) Committee on Standardization of Offshore Safety and Anti-Pollution Equipment. It has been prepared with the overall advisory guidance of the API, Offshore Operators Committee (OOC), and the Western Oil and Gas Association (WOGA). Corrosion related sections were prepared with the assistance of the National Association of Corrosion Engineers (NACE).
- b. This RP contains information for use primarily by design engineers with a working knowledge of production platform operations. Some of the information may be useful to experienced operating personnel. Nothing in this RP is to be construed as a fixed rule without regard to sound engineering judgement nor is it intended to supercede or override any federal, state, or local regulation where applicable.
- c. Conversion of English units to International System (SI) metric units has been omitted to add clarity to graphs and empirical formulas. Factors that may be used for conversion of English units to SI units were taken from API Publication 2564, and are listed below:

**LENGTH**

1 inch (in.) = 25.4 millimetres (mm) exactly

**PRESSURE**

1 pound per square inch (psi) = 0.06894757 Bar

NOTE: 1 Bar = 100 kilopascals (kPa)

**STRENGTH OR STRESS**

1 pound per square inch (psi) = 0.006894757 Megapascals (MPa)

**IMPACT ENERGY**

1 foot-pound (ft-lb) = 1.355818 Joules (J)

**TORQUE**

1 foot-pound (ft-lb) = 1.355818 newton-metres (N·m)

**TEMPERATURE**

The following formula was used to convert degrees Fahrenheit (F) to degrees Celsius (C):  
 $C = 5/9 (F-32)$

**VOLUME**

1 Cubic Foot (cu ft) = 0.02831685 Cubic Metre (m<sup>3</sup>)  
 1 Gallon (gal) = 0.003785412 Cubic Metre (m<sup>3</sup>)  
 1 Barrel (bbl) = 0.1589873 Cubic Metre (m<sup>3</sup>)

**WEIGHT**

1 pound (lb) = 0.4535924 Kilograms (kg)

**FORCE**

1 pound (lb) = 4.448222 Newtons (N)

**FLOW RATE**

1 Barrel per day (BPD) = 0.1589873 Cubic Metres per day (m<sup>3</sup>/d)  
 1 Cubic foot per min (CFM) = 40.77626 Cubic Metres per day (m<sup>3</sup>/d)

**DEFINITIONS**

The following definitions apply specifically to the equipment and systems described in this RP.

- CHLORIDE STRESS CRACKING SERVICE** —Process streams which contain water and chlorides under conditions of concentration and temperature high enough to induce stress cracking of ferrous base alloy materials. Other constituents present, such as oxygen (O<sub>2</sub>), may contribute to such chloride stress cracking.
- CHOKE** —A device specifically intended to restrict the flow rate of fluids.
- CORROSION-EROSION** —The phenomenon of a protective film of corrosion product being eroded away by the erosive action of the process stream, exposing fresh metal which then corrodes. Extremely high metal weight loss may occur under these conditions.
- CORROSIVE GAS** —A gas which when dissolved in water or other liquid causes metal attack. Usually included are hydrogen sulfide (H<sub>2</sub>S), carbon dioxide (CO<sub>2</sub>) and oxygen (O<sub>2</sub>).

- CORROSIVE HYDROCARBON SERVICE** —Process streams which contain water or brine and carbon dioxide (CO<sub>2</sub>), hydrogen sulfide (H<sub>2</sub>S), oxygen (O<sub>2</sub>) or other corrosive agents under conditions which cause metal weight loss.
- DESIGN PRESSURE** —Maximum allowable working pressure at the design temperature.
- EXPANSION BELLOWS** —A corrugated piping device designed for absorbing expansion and contraction.
- EXPANSION BEND** —A piping configuration designed to absorb expansion and contraction.
- FIRE WATCH** —One or more trained persons with operable fire fighting equipment standing on alert during welding or burning operations.
- FLOWLINE** —Piping which carries well fluid from wellhead to manifold or first process vessel.
- FLOW REGIME** —The flow condition of a multiphase process stream such as slug, mist, or stratified flow.
- FLUID** —A generic term meaning a gas, vapor, liquid or combinations thereof.



<b>HEADER</b>	—That part of a manifold which directs fluid to a specific process system. (See Figure 6.1A)	<b>PRESSURE SENSOR</b>	—A device designed to detect a predetermined pressure.
<b>HYDROCARBON WETABILITY</b>	—The ability of the process stream to form a protective hydrocarbon film on metal surfaces.	<b>PROCESS COMPONENT</b>	—A single functional piece of production equipment and associated piping such as a pressure vessel, heater, pump, etc.
<b>MANIFOLD</b>	—An assembly of pipe, valves, and fittings by which fluid from one or more sources is selectively directed to various process systems.	<b>RISER</b>	—The vertical portion of a pipeline (including the bottom bend) arriving on or departing from a platform.
<b>NIPPLE</b>	—A section of threaded or socket welded pipe used as an appurtenance that is less than 12 inches in length.	<b>SHUTDOWN VALVE</b>	—An automatically operated valve used for isolating a process component or process system.
<b>NON-CORROSIVE HYDROCARBON SERVICE</b>	—Process streams under conditions which do not cause significant metal weight loss, selective attack, or stress corrosion cracking.	<b>SULFIDE STRESS CRACKING SERVICE</b>	—Process streams which contain water or brine and hydrogen sulfide (H <sub>2</sub> S) in concentrations high enough to induce stress corrosion cracking of susceptible materials.
<b>PLATFORM PIPING</b>	—A general term referring to any piping, on a platform, intended to contain or transport fluid.	<b>WELLHEAD PRESSURE</b>	—The maximum shut-in surface pressure that may exist in a well.

**SYMBOLS**

The following symbols apply specifically to the equations contained in this RP.

<b>A</b>	= minimum pipe cross-sectional flow area required, inches <sup>2</sup> /1000 barrels fluid/day
<b>B</b>	= mean coefficient of thermal expansion at operating temperatures normally encountered, inches/inch/°F
<b>C</b>	= empirical pump constant
<b>c</b>	= empirical constant
<b>C<sub>v</sub></b>	= valve coefficient (GPM water flow at 60°F across valve with a pressure drop of 1 psi)
<b>d<sub>r</sub></b>	= pipe inside diameter, feet
<b>d<sub>i</sub></b>	= pipe inside diameter, inches
<b>D</b>	= nominal pipe diameter, inches
<b>D<sub>o</sub></b>	= pipe outside diameter, inches
<b>E</b>	= longitudinal weld joint factor, dimensionless
<b>E<sub>m</sub></b>	= modulus of elasticity of piping material in the cold condition, psi
<b>f</b>	= Moody friction factor, dimensionless
<b>g</b>	= gravitational constant, feet/second <sup>2</sup>
<b>GPM</b>	= liquid flow rate, gallons/minute
<b>h<sub>a</sub></b>	= acceleration head, feet of liquid
<b>h<sub>f</sub></b>	= friction head, feet of liquid
<b>h<sub>p</sub></b>	= absolute pressure head, feet of liquid
<b>h<sub>st</sub></b>	= static head, feet of liquid
<b>h<sub>vh</sub></b>	= velocity head, feet of liquid
<b>h<sub>vpa</sub></b>	= absolute vapor pressure, feet of liquid
<b>Δh<sub>w</sub></b>	= differential static pressure head, inches of water
<b>K</b>	= acceleration factor, dimensionless
<b>L</b>	= pipe length, feet
<b>Δ<sub>1</sub></b>	= expansion to be absorbed by pipe, inches
<b>NPSH<sub>a</sub></b>	= available net positive suction head, feet of liquid
<b>P</b>	= operating pressure, psia (See Note (1))
<b>P<sub>1</sub></b>	= internal design pressure, psig
<b>Δp</b>	= pressure drop, psi

<b>ΔP</b>	= pressure drop, psi/100 ft
<b>Q<sub>g</sub></b>	= gas flow rate, million cubic feet/day (14.7 psia and 60°F)
<b>Q<sub>l</sub></b>	= liquid flow rate, barrels/day
<b>q'<sup>h</sup></b>	= gas flow rate, cubic feet/hour (14.7 psia and 60°F)
<b>R</b>	= gas/liquid ratio, standard cubic feet/barrel
<b>Re</b>	= Reynolds number, dimensionless
<b>R<sub>p</sub></b>	= pump speed, revolutions/minute
<b>ρ<sub>g</sub></b>	= gas density at operating pressure and temperature, lbs/ft <sup>3</sup>
<b>ρ<sub>l</sub></b>	= liquid density at operating temperature, lbs/ft <sup>3</sup>
<b>ρ<sub>m</sub></b>	= gas/liquid mixture density at operating pressure and temperature, lbs/ft <sup>3</sup>
<b>S</b>	= allowable stress, psi
<b>S<sub>g</sub></b>	= gas specific gravity (air = 1)
<b>S<sub>l</sub></b>	= liquid specific gravity (water = 1)
<b>T</b>	= operating temperature, °R (See Note (2))
<b>t</b>	= pressure design thickness, inches
<b>ΔT</b>	= temperature change, °F
<b>U</b>	= anchor distance, feet (straight line distance between anchors)
<b>μ<sub>g</sub></b>	= gas viscosity at flowing pressure and temperature, centipoise
<b>μ<sub>l</sub></b>	= liquid viscosity, lbs/ft-sec
<b>V<sub>e</sub></b>	= fluid erosional velocity, feet/second
<b>V<sub>g</sub></b>	= average gas velocity, feet/second (See Note (3))
<b>V<sub>l</sub></b>	= average liquid velocity, feet/second
<b>W</b>	= total liquid plus vapor rate, lbs/hr
<b>Y</b>	= temperature factor, dimensionless
<b>Z</b>	= gas compressibility factor, dimensionless

**NOTES:**

- (1) Also denoted in text as "flowing pressure, psia."
- (2) Also denoted in text as "flowing temperature, °R."
- (3) Also denoted in text as "gas velocity, feet/second."

## SECTION 1 GENERAL

**1.1 Scope.** This document recommends minimum requirements and guidelines for the design and installation of new piping systems on production platforms located offshore. The maximum design pressure within the scope of this document is 10,000 psig and the temperature range is -20°F to 650°F. For applications outside these pressures and temperatures, special consideration should be given to material properties (ductility, carbon migration, etc.). The recommended practices presented are based on years of experience in developing oil and gas leases. Practically all of the offshore experience has been in hydrocarbon service free of hydrogen sulfide. However, recommendations based on extensive experience onshore are included for some aspects of hydrocarbon service containing hydrogen sulfide.

- a. This document contains both general and specific information on surface facility piping systems not specified in API Specification 6A. Sections 2, 3 and 4 contain general information concerning the design and application of pipe, valves, and fittings for typical processes. Sections 6 and 7 contain general information concerning installation, quality control, and items related to piping systems, e.g., insulation, etc. for typical processes. Section 5 contains specific information concerning the design of particular piping systems including any deviations from the recommendations covered in the general sections.
- b. Carbon steel materials are suitable for the majority of the piping systems on production platforms. At least one carbon steel material recommendation is included for most applications. Other materials that may be suitable for platform piping systems have not been included because they are not generally used. The following should be considered when selecting materials other than those detailed in this RP.
  - (1) Type of service.
  - (2) Compatibility with other materials.
  - (3) Ductility.
  - (4) Need for special welding procedures.
  - (5) Need for special inspection, tests, or quality control.
  - (6) Possible misapplication in the field.
  - (7) Corrosion/erosion caused by internal fluids and/or marine environments.

**1.2 Code for Pressure Piping.** The design and installation of platform piping should conform to ANSI B31.3, as modified herein. Risers for which B31.3 is not applicable, should be designed and installed in accordance with the following practices:

- a. Design, construction, inspection and testing should be in accordance with ANSI B31.4, ANSI B31.8, CFR Title 49, Part 192, and/or CFR Title 49, Part 195, as appropriate to the application, using a design stress no greater than 0.6 times SMYS (Specified Minimum Yield Strength).
- b. One hundred percent radiography should be required for welding in accordance with API Std 1104.
- c. Impact tests should be required at the lowest expected operating temperatures for pipe grades higher than X-52.
- d. Valves, fittings and flanges may be manufactured in conformance with MSS (Manufacturers Standardization Society of the Valve and Fit-

tings Industry) standards. Pressure/temperature ratings and material compatibility should be verified.

- e. In determining the transition between risers and platform piping to which these practices apply, the first incoming and last outgoing valve which blocks pipeline flow shall be the limit of this document's application. Recommended Practices included in this document may be utilized for riser design when factors such as water depth, batter of platform legs, potential bubbling area, etc., are considered.

**1.3 Policy.** American Petroleum Institute (API) Recommended Practices are published to facilitate the broad availability of proven, sound, engineering and operating practices. These Recommended Practices are not intended to obviate the need for applying sound judgment as to when and where these Recommended Practices should be utilized.

The formulation and publication of API Recommended Practices is not intended to, in any way, inhibit anyone from using any other practices.

Nothing contained in any API Recommended Practice is to be construed as granting any right, by implication or otherwise, for the manufacture, sale or use in connection with any method, apparatus, or product covered by letters patent, nor as insuring anyone against liability for infringement of letters patent.

This Recommended Practice may be used by anyone desiring to do so, and a diligent effort has been made by API to assure the accuracy and reliability of the data contained herein. However, the Institute makes no representation, warranty or guarantee in connection with the publication of this Recommended Practice and hereby expressly disclaims any liability or responsibility for loss or damage resulting from its use, for any violation of any federal, state or municipal regulation with which an API recommendation may conflict, or for the infringement of any patent resulting from the use of this publication.

**1.4 Industry Codes, Guides and Standards.** Various organizations have developed numerous codes, guides and standards which have substantial acceptance by industry and governmental bodies. Listed below are the codes, guides and standards referenced herein.

Included-by-reference standards shall be the latest published edition unless otherwise stated.

- a. American Iron and Steel Institute.  
AISI Steel Products Manual, *Stainless and Heat Resisting Steels*.
- b. American National Standards Institute (Formerly "ASA" and "USAS").
  - (1) ANSI B2.1, *Pipe Threads*.
  - (2) ANSI B16.5, *Steel Pipe Flanges, Flanged Valves, and Fittings*.
  - (3) ANSI B16.9, *Factory-Made Wrought Steel Butt-welding Fittings*.
  - (4) ANSI B16.10, *Face-to-Face and End-to-End Dimensions of Ferrous Valves*.
  - (5) ANSI B16.11, *Forged Steel Fittings, Socket-Welding and Threaded*.
  - (6) ANSI B16.28, *Wrought Steel Butt-welding Short Radius Elbows and Returns*.
  - (7) ANSI B31.3, *Petroleum Refinery Piping*.
  - (8) ANSI B31.4, *Oil Transportation Piping*.

- (9) ANSI B31.8, *Gas Transmission and Distribution Piping Systems*.
- (10) ANSI B36.10, *Wrought-Steel and Wrought Iron Pipe*.

**c. American Petroleum Institute.**

- (1) API RP 2G, *Recommended Practice for Production Facilities on Offshore Structures*.
- (2) API Bul 5A2, *Bulletin on Thread Compounds for Casing, Tubing, and Line Pipe*.
- (3) API Spec 5B, *Specification for Threading, Gaging, and Thread Inspection of Casing, Tubing, and Line Pipe Threads*.
- (4) API Spec 5L, *Specification for Line Pipe*.
- (5) API Spec 6A, *Specification for Wellhead Equipment*.
- (6) API Spec 6D, *Specification for Pipeline Valves*.
- (7) API RP 14C, *Recommended Practice for Analysis, Design, Installation and Testing of Basic Surface Safety Systems for Offshore Production Platforms*.
- (8) API RP 610, *Pressure Vessel Inspection Code*.
- (9) API RP 520, *Recommended Practice for Design and Installation of Pressure-Relieving Systems in Refineries, Parts I and II*.
- (10) API RP 521, *Guide for Pressure Relief and Depressuring Systems*.
- (11) API Std 526, *Flanged Steel Safety Relief Valves*.
- (12) API RP 550, *Manual on Installation of Refinery Instruments and Control Systems, Parts I and II*.
- (13) API Std 600, *Steel Gate Valves (Flanged or Butt-welding Ends)*.
- (14) API Std 602, *Carbon Steel Gate Valves for Refinery Use (Compact Design)*.
- (15) API Std 1104, *Standard for Welding Pipelines and Related Facilities*.
- (16) API Medical Research Report EA 7301, *Guidelines on Noise*.

**d. American Society for Testing and Materials.**

- (1) ASTM A53, *Specification for Welded and Seamless Steel Pipe*.
- (2) ASTM A105, *Specification for Forgings, Carbon Steel, for Piping Components*.
- (3) ASTM A106, *Specification for Seamless Carbon Steel Pipe for High-Temperature Service*.
- (4) ASTM A158, *Specification for Zinc Coating (Hot-Dip) on Iron and Steel Hardware*.
- (5) ASTM A193, *Specification for Alloy-Steel and Stainless Steel Bolting Materials for High-Temperature Service*.

- (6) ASTM A194, *Specification for Carbon and Alloy Steel Nuts for Bolts for High-Pressure and High-Temperature Service*.
- (7) ASTM A234, *Specification for Piping Fittings of Wrought Carbon Steel and Alloy Steel for Moderate and Elevated Temperatures*.
- (8) ASTM A333, *Specification for Seamless and Welded Steel Pipe for Low-Temperature Service*.
- (9) ASTM A354, *Specification for Quenched and Tempered Alloy Steel Bolts, Studs, and Other Externally Threaded Fasteners*.

**e. American Society of Mechanical Engineers.**

- (1) ASME Boiler and Pressure Vessel Code, Section IV, *Heating*.
- (2) ASME Boiler and Pressure Vessel Code, Section VIII, *Pressure Vessels, Division 1*.
- (3) ASME Boiler and Pressure Vessel Code, Section IX, *Qualification Standard for Welding and Brazing Procedures, Welders, Brazers, and Welding and Brazing Operators*.

**f. National Association of Corrosion Engineers**

- (1) NACE Std MR-01-75, *Sulfide Stress Cracking Resistant Metallic Materials for Oil Field Equipment*.
- (2) NACE Std. RP-01-76, *Corrosion Control on Steel, Fixed Offshore Platforms Associated with Petroleum Production*.

**g. National Fire Protection Association.**

- (1) National Fire Code Volume 6, *Sprinklers, Fire Pumps and Water Tanks*.
- (2) National Fire Code Volume 8, *Portable and Manual Fire Control Equipment*.

**h. Gas Processors Suppliers Association (formerly Natural Gas Processors Suppliers Association). Engineering Data Books.**

**i. Hydraulics Institute.**

- (1) *Standards for Centrifugal, Rotary and Reciprocating Pumps*.
- (2) *Pipe Friction Manual*.

**1.5 Governmental Rules and Regulations.** Regulatory agencies have established certain rules and regulations which may influence the nature and manner in which platform piping is installed and operated. Listed below are references to significant rules and regulations which should be considered in the design and installation of platform piping, where applicable.

**a. Code of Federal Regulations.**

- (1) Title 29, Part 1910, *Occupational Safety and Health Standards*.
- (2) Title 30, Part 250, *Oil and Gas and Sulfur Operations in the Outer Continental Shelf*.
- (3) Title 33, Subchapter C, *Aids to Navigation, Part 67, Aids to Navigation on Artificial Islands and Fixed Structures*.

- (4) Title 33, Subchapter N, *Artificial Islands and Fixed Structures on the Outer Continental Shelf*, Parts 140 through 146.
- (5) Title 33, Part 153, *Control of Pollution by Oil and Hazardous Substances, Discharge Removal*.
- (6) Title 40, Part 110, *Discharge of Oil*.
- (7) Title 40, Part 112, *Oil Pollution Prevention*.
- (8) Title 49, Part 192, *Transportation of Natural and Other Gas by Pipeline: Minimum Federal Safety Standards*.
- (9) Title 49, Part 195, *Transportation of Liquids by Pipeline*.

b. Environmental Protection Agency. Document AP-26, *Workbook of Atmospheric Dispersion Estimates*.

c. Regional Outer Continental Shelf Orders Promulgated Under the Code of Federal Regulations, Title 30, Part 250, *Oil and Gas Sulphur Operations in the Outer Continental Shelf*.

d. State, municipal and other local regulatory agencies, as applicable.

**1.6 Demarcation Between Systems with Different Pressure Ratings.** Normally after the wellstream leaves the wellhead, the pressure is reduced in stages.

After the pressure is reduced, process components of lower pressure rating may be used. A typical example is shown in Figure 1.1

- a. One rule can be used for pressure design: a pressure containing process component should either be designed to withstand the maximum internal pressure which can be exerted on it under any conditions, or be protected by a pressure relieving device. In this case, a pressure relieving device means a safety relief valve or a rupture disc. In general, when determining if pressure relieving devices are needed, high pressure shutdown valves, check valves, control valves or other such devices should not be considered as preventing overpressure of process components. See API RP 14C for recommended practices concerning required safety devices for process components.
- b. One good way to analyze required system design pressure ratings for process components is to show pressure rating boundaries on mechanical flow sheets. Each component (vessels, flanges, pipe or accessories) may then be checked to determine that it is either designed to withstand the highest pressure to which it could be subjected, or is protected by a pressure relieving device.

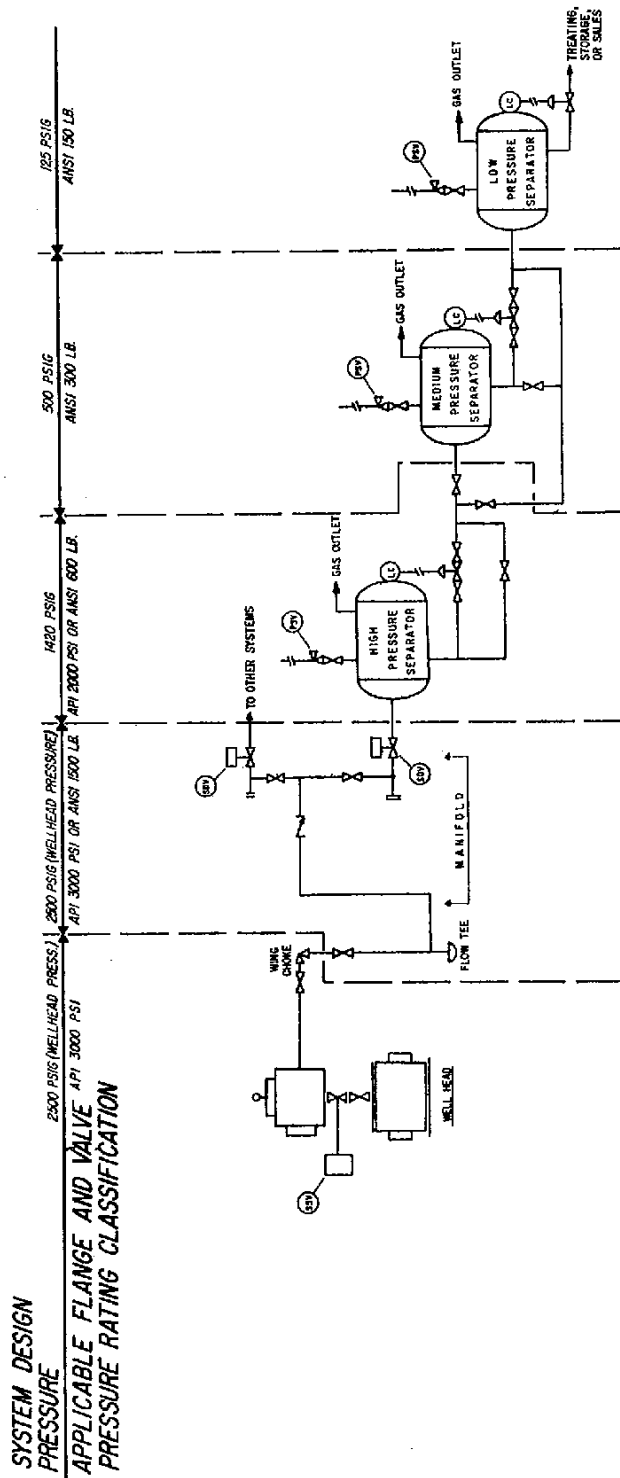

**NOTES**

1. Design temperature is 150° F throughout.
2. Required shutdown sensors are not shown.
3. Flowline and manifold are designed for wellhead pressure.
4. System design pressures may be limited by factors other than the flange and valve pressure classifications (i.e. pipe wall thickness, separator design pressure, etc.).
5. Relief valves must be set no higher than system design pressure.
6. Valves under relief valves must be locked open.

**FIGURE 1.1  
EXAMPLE PROCESS SYSTEM  
DENOTING FLANGE AND VALVE PRESSURE RATING CHANGES**

1.7 Corrosion Considerations.

a. General. Detailed corrosion control practices for platform piping systems are outside the scope of this recommended practice. Such practices should, in general, be developed by corrosion control specialists. Platform piping systems should, however, be designed to accommodate and to be compatible with the corrosion control practices described below. Suggestions for corrosion resistant materials and mitigation practices are given in the appropriate sections of this RP.

NOTE: *The corrosivity of process streams may change with time. The possibility of changing conditions should be considered at the design stage.*

b. Weight Loss Corrosion. Carbon steel which is generally utilized for platform piping systems may corrode under some process conditions. Production process streams containing water, brine, carbon dioxide (CO<sub>2</sub>), hydrogen sulfide (H<sub>2</sub>S), or oxygen (O<sub>2</sub>), or combinations of these, may be corrosive to metals used in system components. The type of attack (uniform metal loss, pitting, corrosion/erosion, etc.) as well as the specific corrosion rate may vary in the same system, and may vary with time. The corrosivity of a process stream is a complex function of many variables including (1) hydrocarbon, water, salt, and corrosive gas content, (2) hydrocarbon wettability, (3) flow velocity, flow regime, and piping configuration, (4) temperature, pressure, and pH, and (5) solids content (sand, mud, bacterial slime and microorganisms, corrosion products, and scale). Corrosivity predictions are very qualitative and may be unique for each system. Some corrosivity information for corrosive gases found in production streams is shown in Table 1.1.

Table 1.1 is intended only as a general guide for corrosion mitigation considerations and not for specific corrosivity predictions. Corrosion inhibition is an effective mitigation procedure when corrosive conditions are predicted or anticipated (See Paragraph 2.1.b).

c. Sulfide Stress Cracking. Process streams containing water and hydrogen sulfide may cause sulfide stress cracking of susceptible materials. This phenomenon is affected by a complex interaction of parameters including metal chemical composition and hardness, heat treatment, and microstructure, as well as factors such as pH,

TABLE 1.1  
QUALITATIVE GUIDELINE FOR WEIGHT LOSS CORROSION OF STEEL

Corrosive gas	Solubility* PPM	Limiting Values in Brine	
		Non-corrosive PPM	Corrosive PPM
Oxygen (O <sub>2</sub> )	8	<0.005	>0.025
Carbon Dioxide (CO <sub>2</sub> )	1700	<600	>1200
Hydrogen Sulfide (H <sub>2</sub> S)	3900	**	**

\*Solubility at 68°F in distilled water at 1 atmosphere partial pressure. Oxygen (O<sub>2</sub>) is for 1 atmosphere air pressure. Source: Handbook of Chemistry and Physics, Chemical Rubber Company, 88th Edition.

\*\*No limiting values for weight loss corrosion by hydrogen sulfide (H<sub>2</sub>S) are shown in this table because the amount of carbon dioxide (CO<sub>2</sub>) and/or oxygen (O<sub>2</sub>) greatly influences the metal loss corrosion rate. Hydrogen sulfide alone is usually less corrosive than carbon dioxide due to the formation of an insoluble iron sulfide film which tends to reduce metal weight loss corrosion.

hydrogen sulfide concentration, stress and temperature. Materials used to contain process streams containing hydrogen sulfide should be selected to accommodate these parameters.

d. Chloride Stress Cracking. Careful consideration should be given to the effect of stress and chlorides if alloy and stainless steels are selected to prevent corrosion by hydrogen sulfide and/or carbon dioxide. Process streams which contain water with chlorides may cause cracking in susceptible materials, especially if oxygen is present and the temperature is over 140°F. High alloy and stainless steels, such as the AISI 300 series austenitic stainless steels, precipitation hardening stainless steels, and "A-286" (ASTM A453, Grade 660), should not be used unless their suitability in the proposed environment has been adequately demonstrated. Consideration should also be given to the possibility that chlorides may be concentrated in localized areas in the system.

e. Application of NACE MR-01-75. MR-01-75 lists materials which exhibit resistance to sulfide stress cracking. Corrosion resistant alloys not listed in MR-01-75 may exhibit such resistance and may be used if it can be demonstrated that they are resistant in the proposed environment of use (or in an equivalent laboratory environment). Caution should be exercised in the use of materials listed in MR-01-75. The materials listed in the document may be resistant to sulfide stress corrosion environments, but may not be suitable for use in chloride stress cracking environments.

## SECTION 2

### PIPING DESIGN

#### 2.1 Pipe Grades.

**a. Non-Corrosive Hydrocarbon Service.** The two most commonly used types of pipe are ASTM A106, Grade B, and API 5L, Grade B. Seamless pipe is generally preferred due to its consistent quality. ASTM A106 is only manufactured in seamless while API 5L is available in seamless, electric resistance welded (ERW) and submerged arc welded (SAW). When use of Grade B requires excessive wall thickness, higher strength pipe such as API 5L, Grade X52, may be required; however, special welding procedures and close supervision are necessary when using API 5L, Grade X46, or higher.

Many of the grades of pipe listed in ANSI B31.3 are suitable for non-corrosive hydrocarbon service. The following types or grades of pipe are specifically excluded from hydrocarbon service by ANSI B31.3:

- (1) All grades of ASTM A120.
- (2) Furnace lap weld and furnace butt weld.
- (3) Fusion weld per ASTM A134 and A139.
- (4) Spiral weld, except API 5L spiral weld.

**b. Corrosive Hydrocarbon Service.** Design for corrosive hydrocarbon service should provide for one or more of the following corrosion mitigating practices: (1) chemical treatment; (2) corrosion resistant alloys; (3) protective coatings (See Paragraph 6.5.b). Of these, chemical treatment of the fluid in contact with carbon steels is by far the most common practice and is generally recommended. Corrosion resistant alloys which have proven successful in similar applications (or by suitable laboratory tests) may be used. If such alloys are used, careful consideration should be given to welding procedures. Consideration should also be given to the possibility of sulfide and chloride stress cracking (See Paragraphs 1.7.c and 1.7.d). Adequate provisions should be made for corrosion monitoring (coupons, probes, spools, etc.) and chemical treating.

**c. Sulfide Stress Cracking Service.** The following guidelines should be used when selecting pipe if sulfide stress corrosion cracking is anticipated:

- (1) Only seamless pipe should be used unless quality control applicable to this service has been exercised in manufacturing ERW or SAW pipe.
- (2) Cold expanded pipe should not be used unless followed by normalizing, quenching and tempering, tempering, or heat treatment as described in 2.1.c(4).
- (3) Carbon and alloy steels and other materials which meet the property, hardness, heat treatment and other requirements of NACE MR-01-75 are acceptable for use in sulfide stress cracking service.
- (4) Materials not meeting the metallurgical requirements of NACE MR-01-75 may be used; however, usage should be limited to appli-

cations or systems in which the external environment and the process stream can be continuously maintained to assure freedom from sulfide stress cracking, or limited to those materials for which adequate data exists to demonstrate resistance to sulfide or chloride stress cracking in the application or system environments to which the materials are exposed, (See MR-01-75).

The most commonly used pipe grades which will meet the above guidelines are: ASTM A106, Grade B; ASTM A333, Grade 1; and API 5L, Grade B, seamless. API 5L X grades are also acceptable; however, welding presents special problems. To enhance toughness and reduce brittle fracture tendencies, API 5L pipe should be normalized for service temperatures below 30° F. ASTM A333, Grade 1, is a cold service piping material and should have adequate notch toughness in the temperature range covered by this RP (-20° to 650° F).

**d. Utilities Service.** Materials other than carbon steel are commonly used in utilities service. If, however, steel pipe is used that is of a type or grade not acceptable for hydrocarbon service in accordance with Paragraph 2.1.a, some definite marking system should be established to prevent such pipe from accidentally being used in hydrocarbon service. One way to accomplish this would be to have all such pipe galvanized.

**e. Tubing.** AISI 316 or AISI 316L stainless steel, seamless or electric resistance welded tubing is preferred for all hydrocarbon service, and air service exposed to sunlight. Tubing used for air service not exposed to sunlight, or instrument tubing used for gas service contained in an enclosure, may be made of other materials. If used, synthetic tubing should be selected to withstand degradation caused by the contained fluids and the temperature to which it may be subjected.

**2.2 Sizing Criteria—General.** In determining the diameter of pipe to be used in platform piping systems, both the flow velocity and pressure drop should be considered. Sections 2.3, 2.4 and 2.5 present equations for calculating pipe diameters (and graphs for rapid approximation of pipe diameters) for liquid lines, single-phase gas lines, and gas/liquid two-phase lines, respectively. Many companies also use computer programs to facilitate piping design.

**a.** When determining line sizes, the maximum flow rate expected during the life of the facility should be considered rather than the initial flow rate. It is also usually advisable to add a surge factor of 20 to 50 percent to the anticipated normal flow rate, unless surge expectations have been more precisely determined by pulse pressure measurements in similar systems or by specific fluid hammer calculation. Table 2.1 presents some typical surge factors that may be used if more definite information is not available.

In large diameter flow lines producing liquid-vapor phase fluids between platforms through riser systems, surge factors have been known to exceed 200% due to slug flow. Refer to liquid-vapor slug flow programs generally available to Industry for evaluation of slug flow.

**TABLE 2.1**  
**TYPICAL SURGE FACTORS**

Service	Factor
Facility handling primary production from its own platform	20%
Facility handling primary production from another platform or remote well in less than 150 feet of water	30%
Facility handling primary production from another platform or remote well in greater than 150 feet of water	40%
Facility handling gas lifted production from its own platform	40%
Facility handling gas lifted production from another platform or remote well	50%

- b. Determination of pressure drop in a line should include the effect of valves and fittings. Manufacturer's data or an equivalent length given in Table 2.2 may be used.
- c. Calculated line sizes may need to be adjusted in accordance with good engineering judgment.

**2.3 Sizing Criteria For Liquid Lines.**

a. **General.** Single-phase liquid lines should be sized primarily on the basis of flow velocity. For lines transporting liquids in single-phase from one pressure vessel to another by pressure differential, the flow velocity should not exceed 15 feet/second at maximum flow rates, to minimize flashing ahead of the control valve. If practical, flow velocity should not be less than 3 feet/second to minimize deposition of sand and other solids. At these flow velocities, the overall pressure drop in the piping will usually be small. Most of the pressure drop in liquid lines between two pressure vessels will occur in the liquid dump valve and/or choke.

- (1) Flow velocities in liquid lines may be read from Figure 2.1 or may be calculated using the following derived equation:

$$V_1 = \frac{.012 Q_1}{d_i^2} \quad \text{Eq. 2.1}$$

where:

- $V_1$  = average liquid flow velocity, feet/second.
- $Q_1$  = liquid flow rate, barrels/day.
- $d_i$  = pipe inside diameter, inches.

- (2) Pressure drop (psi per 100 feet of flow length) for single phase liquid lines may be read from Figure 2.2 or may be calculated using the following (Fanning) equation:

$$\Delta P = \frac{0.00115f Q_1^2 S_1}{d_i^5} \quad \text{Eq. 2.2}$$

where:

- $\Delta P$  = pressure drop, psi/100 feet.
- $f$  = Moody friction factor, dimensionless.
- $Q_1$  = liquid flow rate, barrels/day.
- $S_1$  = liquid specific gravity (water = 1).
- $d_i$  = pipe inside diameter, inches.

- (3) The Moody friction factor,  $f$ , is a function of the Reynolds number and the surface roughness of the pipe. The modified Moody diagram, Figure 2.3, may be used to determine the friction factor once the Reynolds number is known. The Reynolds number may be determined by the following equation:

$$Re = \frac{\rho_l d_i V_1}{\mu} \quad \text{Eq. 2.3}$$

where:

- $Re$  = Reynolds number, dimensionless.
- $\rho_l$  = liquid density, lb/ft<sup>3</sup>.
- $d_i$  = pipe inside diameter, ft.
- $V_1$  = liquid flow velocity, ft/sec.
- $\mu$  = liquid viscosity, lb/ft-sec, or  
= centipoise divided by 1488, or  
= (centistokes times specific gravity) divided by 1488.

- b. **Pump Piping.** Reciprocating, rotary and centrifugal pump suction piping systems should be designed so the available net positive suction head (NPSH) at the pump inlet flange exceeds the pump required NPSH. Additionally, provisions should be made in reciprocating pump suction piping to minimize pulsations. Satisfactory pump operation requires that essentially no vapor be flashed from the liquid as it enters the pump casing or cylinder.

- (1) In a centrifugal or rotary pump, the liquid pressure at the suction flange must be high enough to overcome the pressure drop between the flange and the entrance to the impeller vane (or rotor) and maintain the pressure on the liquid above its vapor pressure. Otherwise cavitation will occur. In a reciprocating unit, the pressure at the suction flange must meet the same requirement; but the pump required NPSH is typically higher than for a centrifugal pump because of pressure drop across the valves and pressure drop caused by pulsation in the flow. Similarly, the available NPSH supplied to the pump suction must account for the acceleration in the suction piping caused by the pulsating flow, as well as the friction, velocity and static head.
- (2) The necessary available pressure differential over the pumped fluid vapor pressure may be defined as net positive suction head available (NPSH<sub>a</sub>). It is the total head in feet absolute determined at the suction nozzle, less the vapor pressure of the liquid in feet absolute. Available NPSH should always equal or exceed the pump's required NPSH. Available NPSH for most pump applications may be calculated using Equation 2.4.

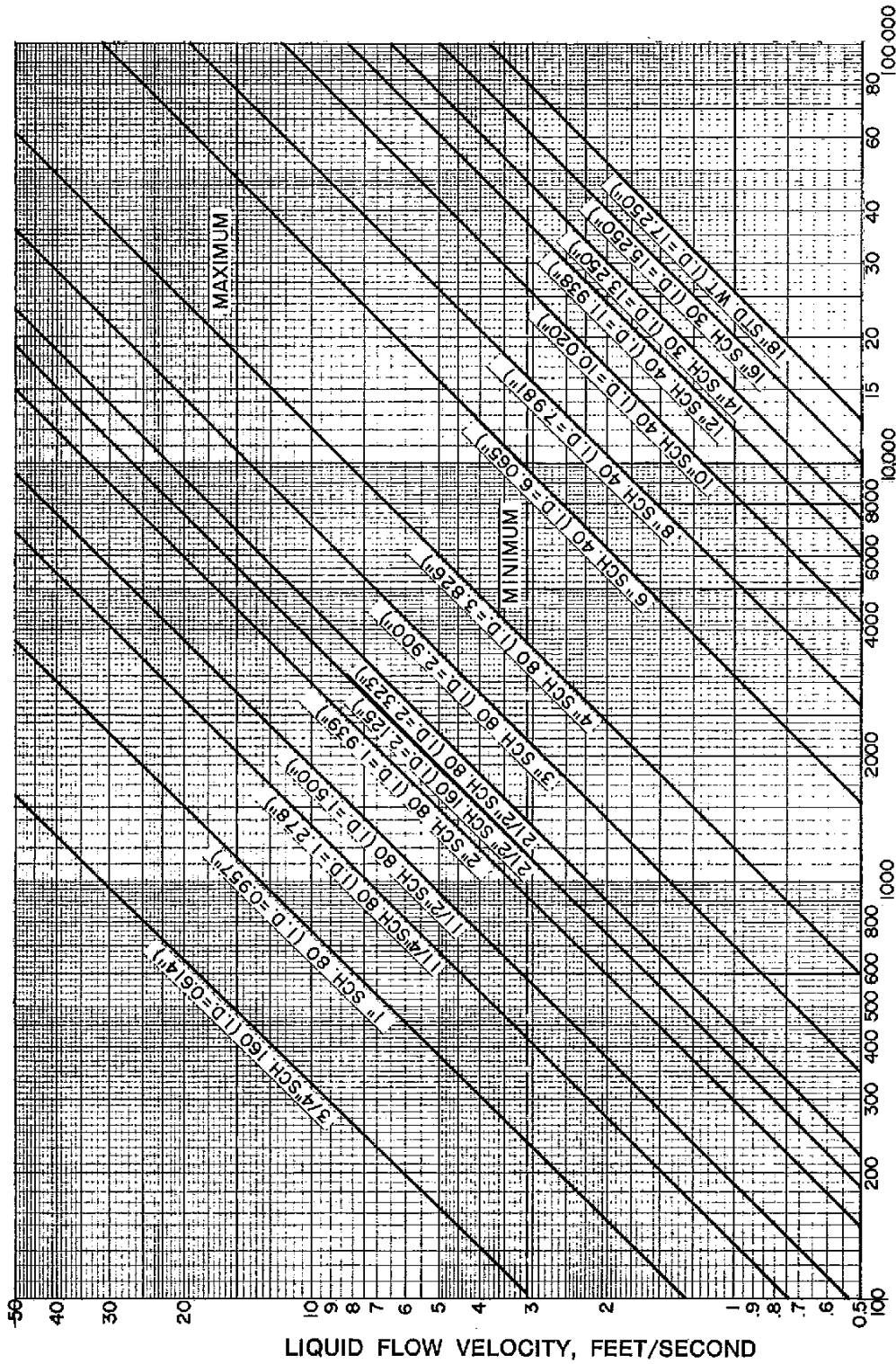

TABLE 2.2  
EQUIVALENT LENGTH OF 100 PERCENT  
OPENING VALVES AND FITTINGS IN FEET

Nominal Pipe Size (inches)	Globe Valve or Ball Check Valve	Angle Valve	Swing Check Valve	Plug Valve, Gate Valve or Ball Valve	45° Ell		Short Radius Ell		Long Radius Ell		Branch of Tee		Run of Tee		Enlargement						Contraction								
					45° Ell		Short Radius Ell		Long Radius Ell		Branch of Tee		Run of Tee		Sudden			Standard Reducer			Sudden			Standard Reducer					
					Weld	Thread	Weld	Thread	Weld	Thread	Weld	Thread	Weld	Thread	Weld	Thread	Weld	Thread	d/D=1/4	d/D=1/2	d/D=3/4	d/D=1/4	d/D=1/2	d/D=3/4	d/D=1/4	d/D=1/2	d/D=3/4	d/D=1/4	d/D=1/2
1 1/2	55	26	13	1	1	2	3	2	3	2	3	2	3	2	3	5	3	1	4	1	3	1	3	1	1	1	1		
2	70	33	17	2	2	3	4	3	4	3	4	3	4	3	4	7	4	1	5	1	3	1	3	1	1	1	1		
2 1/2	80	40	20	2	2	5	5	3	4	3	4	3	4	3	4	8	5	2	6	2	4	2	4	2	2	2	2	2	
3	100	50	25	2	2	6	6	4	4	4	4	4	4	4	10	6	2	8	2	5	2	5	2	4	2	2	2	2	
4	130	65	32	3	3	7	7	5	5	5	5	5	5	5	12	8	3	10	3	6	3	6	3	5	3	3	3	3	
6	200	100	48	4	4	11	11	8	8	8	8	8	8	8	18	12	4	14	4	9	4	9	4	7	4	4	4	4	4
8	260	125	64	6	6	15	15	9	9	9	9	9	9	9	25	16	5	19	5	12	5	12	5	9	5	5	5	5	5
10	330	160	80	7	7	18	18	12	12	12	12	12	12	12	31	20	7	24	7	15	7	15	7	12	7	6	6	6	6
12	400	190	95	9	9	22	22	14	14	14	14	14	14	14	37	24	8	28	8	18	8	18	8	14	8	7	7	7	7
14	450	210	105	10	10	26	26	16	16	16	16	16	16	16	42	26	9	30	9	20	9	20	9	16	9	8	8	8	8
16	500	240	120	11	11	29	29	18	18	18	18	18	18	18	47	30	10	30	10	24	10	24	10	24	10	9	9	9	9
18	550	280	140	12	12	33	33	20	20	20	20	20	20	20	53	35	11	35	11	26	11	26	11	26	10	10	10	10	10
20	650	300	155	14	14	36	36	23	23	23	23	23	23	23	60	38	13	38	13	30	13	30	13	30	11	11	11	11	11
22	688	335	170	15	15	40	40	25	25	25	25	25	25	25	65	42	14	42	14	32	14	32	14	32	12	12	12	12	12
24	750	370	185	16	16	44	44	27	27	27	27	27	27	27	70	46	15	46	15	35	15	35	15	35	13	13	13	13	13
30				21	21	55	55	40	40	40	40	40	40	40	140	60	21	60	21	40	21	40	21	40	11	11	11	11	11
36				25	25	66	66	47	47	47	47	47	47	47	170	70	25	70	25	55	25	55	25	55	13	13	13	13	13
42				30	30	77	77	55	55	55	55	55	55	55	200	80	30	80	30	65	30	65	30	65	15	15	15	15	15
48				35	35	88	88	65	65	65	65	65	65	65	220	90	35	90	35	70	35	70	35	70	15	15	15	15	15
54				40	40	99	99	70	70	70	70	70	70	70	250	100	40	100	40	80	40	80	40	80	15	15	15	15	15
60				45	45	110	110	80	80	80	80	80	80	80	260	110	45	110	45	80	45	80	45	80	15	15	15	15	15

NOTES:

- Source of data is GPSA Data Book, 1981 Revision.
- d is inside diameter of smaller outlet.  
D is inside diameter of larger outlet.



LIQUID FLOW RATE, BARRELS FLUID/DAY

(NOTE: These curves were determined using Equation 2.1)

FIGURE 2.1

VELOCITY IN LIQUID LINES

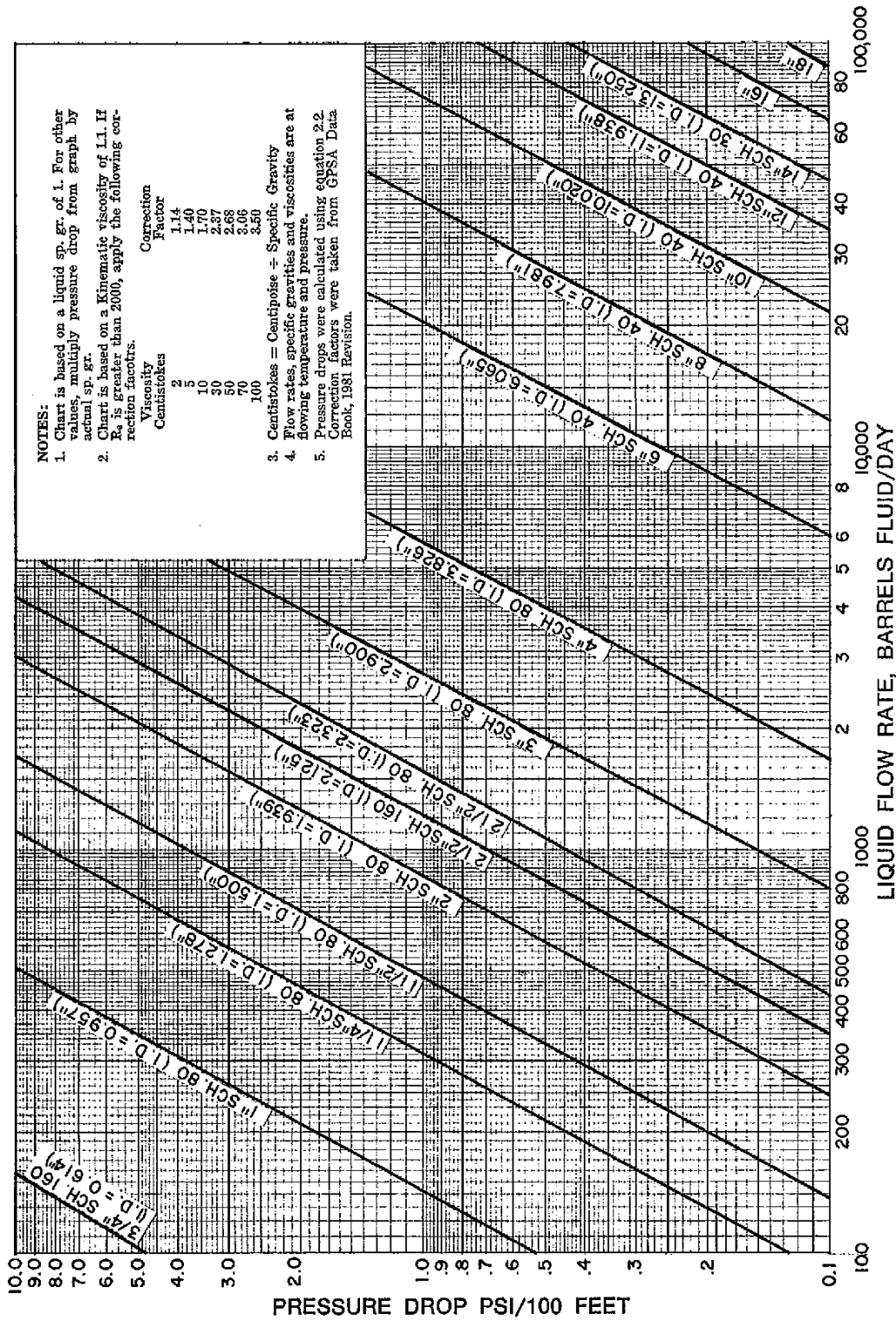

FIGURE 2.2  
PRESSURE DROP IN LIQUID LINES

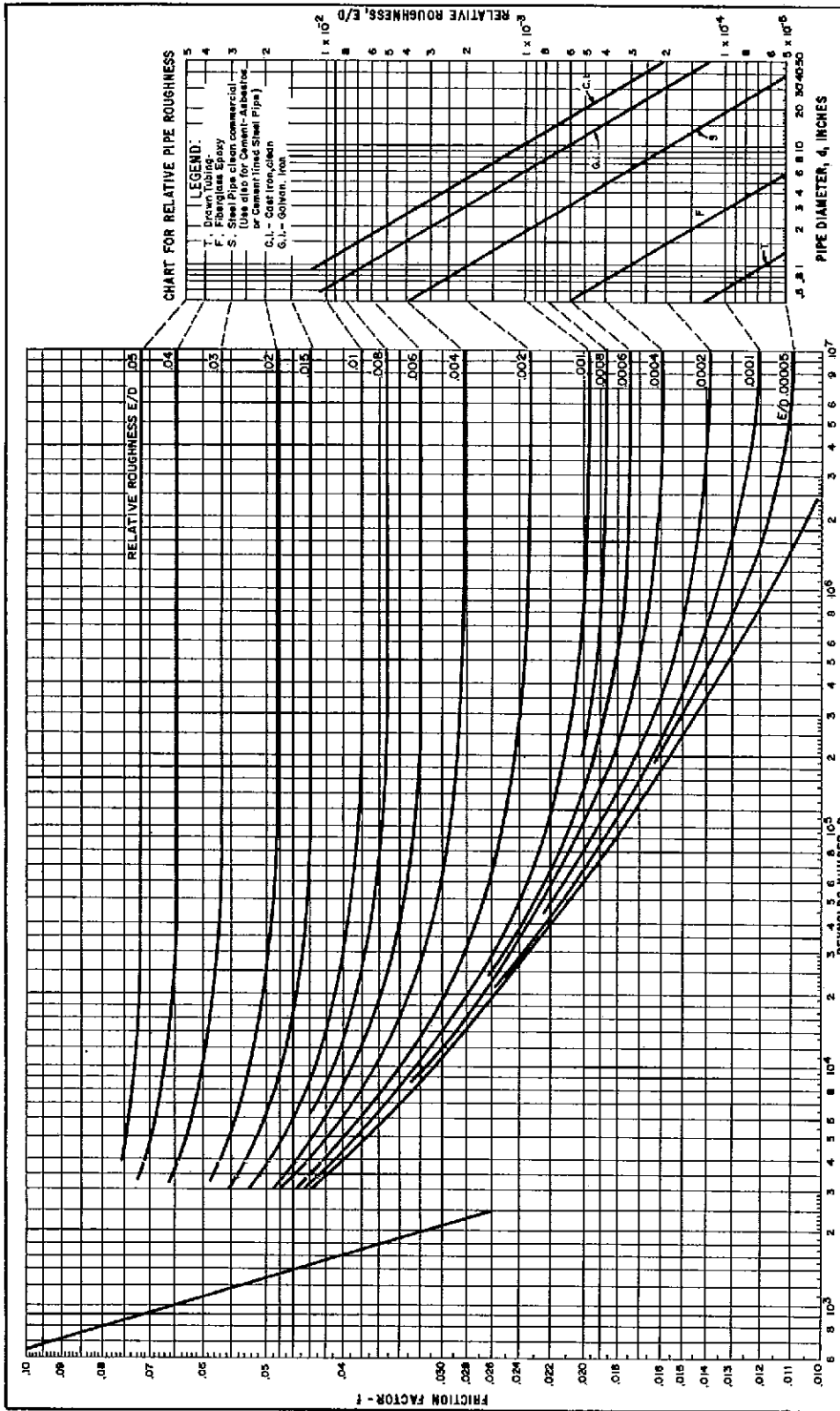

FIGURE 2.3  
FRICTION FACTOR CHART  
(Modified Moody Diagram)

$$NPSH_a = h_p - h_{vpa} + h_{st} - h_f - h_{vh} - h_a \quad \text{Eq. 2.4}$$

where:

- $h_p$  = absolute pressure head due to pressure, atmospheric or otherwise, on surface of liquid going to suction, feet of liquid.
- $h_{vpa}$  = the absolute vapor pressure of the liquid at suction temperature, feet of liquid.
- $h_{st}$  = static head, positive or negative, due to liquid level above or below datum line (centerline of pump), feet of liquid.
- $h_f$  = friction head, or head loss due to flowing friction in the suction piping, including entrance and exit losses, feet of liquid.
- $h_{vh}$  = velocity head =  $\frac{V_1^2}{2g}$ , feet of liquid.
- $h_a$  = acceleration head, feet of liquid.
- $V_1$  = velocity of liquid in piping, feet/second.
- $g$  = gravitational constant (usually 32.2 feet/second<sup>2</sup>).

- (3) For a centrifugal or rotary pump, the acceleration head,  $h_a$ , is zero. For reciprocating pumps, the acceleration head is critical and may be determined by the following equation from the Hydraulics Institute:

$$h_a = \frac{LV_1R_pC}{Kg} \quad \text{Eq. 2.5}$$

where:

- $h_a$  = acceleration head, feet of liquid.
- $L$  = length of suction line, feet (actual length, not equivalent length).
- $V_1$  = average liquid velocity in suction line, feet/second.
- $R_p$  = pump speed, revolutions/minute.
- $C$  = empirical constant for the type of pump:
  - = .200 for simplex double acting;
  - = .200 for duplex single acting;
  - = .115 for duplex double acting;
  - = .066 for triplex single or double acting;
  - = .040 for quintuplex single or double acting;
  - = .028 for septuplex single or double acting.
- NOTE: The constant  $C$  will vary from these values for unusual ratios of connecting rod length to crank radius.
- $K$  = a factor representing the reciprocal of the fraction of the theoretical acceleration head which must be provided to avoid a noticeable disturbance in the suction piping:
  - = 1.4 for liquid with almost no compressibility (deaerated water);
  - = 1.5 for amine, glycol, water;

- = 2.0 for most hydrocarbons;
- = 2.5 for relatively compressible liquid (hot oil or ethane).
- $g$  = gravitational constant (usually 32.2 feet/second<sup>2</sup>).

It should be noted that there is not universal acceptance of Equation 2.5 or of the effect of acceleration head (See References b, c and d, Section 2.10). However, Equation 2.5 is believed to be a conservative basis which will assure adequate provision for acceleration head.

- (4) When more than one reciprocating pump is operated simultaneously on a common feed line, at times all crankshafts are in phase and, to the feed system, the multiple pumps act as one pump of that type with a capacity equal to that of all pumps combined. In this case, the maximum instantaneous velocity in the feed line would be equal to that created by one pump having a capacity equal to that of all the pumps combined.
- (5) If the acceleration head is determined to be excessive, the following should be evaluated:
  - (a) Shorten suction line. Acceleration head is directly proportional to line length,  $L$ .
  - (b) Use larger suction pipe to reduce velocity. This is very helpful since velocity varies inversely with the square of pipe inside-diameter. Acceleration head is directly proportional to fluid velocity,  $V_1$ .
  - (c) Reduce required pump speed by using a larger size piston or plunger, if permitted by pump rating. Speed required is inversely proportional to the square of piston diameter. Acceleration head is directly proportional to pump speed,  $R_p$ .
  - (d) Consider a pump with a larger number of plungers. For example:  $C = .040$  for a quintuplex pump. This is about 40% less than  $C = .066$  for a triplex pump. Acceleration head is directly proportional to  $C$ .
  - (e) Consider using a pulsation dampener if the above remedies are unacceptable. The results obtainable by using a dampener in the suction system depend on the size, type, location, and charging pressure used. A good, properly located dampener, if kept properly charged, may reduce  $L$ , the length of pipe used in acceleration head equation, to a value of 5 to 15 nominal pipe diameters. Dampeners should be located as close to the pump suction as possible.
  - (f) Use a centrifugal booster pump to charge the suction of the reciprocating pump.
- (6) The following guidelines may be useful in designing suction piping:
  - (a) Suction piping should be one or two pipe sizes larger than the pump inlet connection.

- (b) Suction lines should be short with a minimum number of elbows and fittings.
  - (c) Eccentric reducers should be used near the pump, with the flat side up to keep the top of the line level. This eliminates the possibility of gas pockets being formed in the suction piping. If potential for accumulation of debris is a concern, means for removal is recommended.
  - (d) For reciprocating pumps, provide a suitable pulsation dampener (or make provisions for adding a dampener at a later date) as close to the pump cylinder as possible.
  - (e) In multi-pump installations, size the common feed line so the velocity will be as close as possible to the velocity in the laterals going to the individual pumps. This will avoid velocity changes and thereby minimize acceleration head effects.
- (7) Reciprocating, centrifugal and rotary pump discharge piping should be sized on an economical basis. Additionally, reciprocating pump discharge piping should be sized to minimize pulsations. Pulsations in reciprocating pump discharge piping are also related to the acceleration head, but are more complex than suction piping pulsations. The following guidelines may be useful in designing discharge piping:
- (a) Discharge piping should be as short and direct as possible.
  - (b) Discharge piping should be one or two pipe sizes larger than pump discharge connection.
  - (c) Velocity in discharge piping should not exceed three times the velocity in the suction piping. This velocity will normally result in an economical line size for all pumps, and will minimize pulsations in reciprocating pumps.
  - (d) For reciprocating pumps, include a suitable pulsation dampener (or make provisions for adding a dampener at a later date) as close to the pump cylinder as possible.
- (8) Table 2.3 may be used to determine preliminary suction and discharge line sizes.

TABLE 2.3  
TYPICAL FLOW VELOCITIES

	Suction Velocity (feet per second)	Discharge Velocity (feet per second)
<b>Reciprocating Pumps</b>		
Speeds up to 250 RPM.....	2	6
Speeds 251-330 RPM.....	1½	4½
Speeds above 330 RPM.....	1	3
<b>Centrifugal Pumps</b> .....	2-3	6-9

**2.4 Sizing Criteria for Single-Phase Gas Lines.** Single-phase gas lines should be sized so that the resulting end pressure is high enough to satisfy the requirements of the next piece of equipment. Also velocity may

be a noise problem if it exceeds 60 feet/second; however, the velocity of 60 feet/second should not be interpreted as an absolute criteria. Higher velocities are acceptable when pipe routing, valve choice and placement are done to minimize or isolate noise.

The design of any piping system where corrosion inhibition is expected to be utilized should consider the installation of additional wall thickness in piping design and/or reduction of velocity to reduce the effect of stripping inhibitor film from the pipe wall. In such systems it is suggested that a wall thickness monitoring method be instituted.

**a. General Pressure Drop Equation.**

$$P_1^2 - P_2^2 = 25.2 \frac{S Q_g^2 Z T_1 f L}{d^5} \quad \text{Eq. 2.6}$$

where:

- $P_1$  = upstream pressure, psia
- $P_2$  = downstream pressure, psia
- $S$  = gas specific gravity at standard conditions
- $Q_g$  = gas flow rate, MMscfd (at 14.7 psig and 60°F)
- $Z$  = compressibility factor for gas (Refer to GPSA Engineering Data Book)
- $T_1$  = flowing temperature, °R
- $f$  = Moody friction factor, dimensionless (refer to Figure 2.3)
- $d$  = pipe ID, in.
- $L$  = length, feet

Rearranging Equation 2.6 and solving for  $Q_g$  we have:

$$Q_g = 0.199 \left[ \frac{d^5 (P_1^2 - P_2^2)}{Z T_1 f L S} \right]^{1/2} \quad \text{Eq. 2.7}$$

An approximation of Equation 2.6 can be made when the change in pressure is less than 10% of the inlet pressure. If this is true, we can make the assumption:

$$P_1^2 - P_2^2 \approx 2P_1 (P_1 - P_2) \quad \text{Eq. 2.8}$$

Substituting in Equation 2.6 we have:

$$\Delta P = 12.6 \frac{S Q_g^2 Z T_1 f L}{P_1 d^5} \quad \text{Eq. 2.9}$$

**b. Empirical Pressure Drop.** Several empirical equations have been developed so as to avoid solving for the Moody Friction Factor. All equations are patterned after the general flow equation with various assumptions relative to the Reynolds Number. The most common empirical pressure drop equation for gas flow in production facility piping is the Weymouth Equation described below:

**1. Weymouth Equation.**

This equation is based on measurements of compressed air flowing in pipes ranging from 0.8 inches to 11.8 inches in the range of the Moody diagram where the  $\xi/d$  curves are horizontal (i.e., high Reynolds number). In this range the Moody friction factor is independent of the Reynolds number and dependent upon the relative roughness.

The Weymouth equation can be expressed as:

$$Q_g = 1.11 d^{2.87} \left[ \frac{P_1^2 - P_2^2}{LSZT_1} \right]^{1/2} \quad \text{Eq. 2.10}$$

where:

- $Q_g$  = flow rate, MMscfd (at 14.7 psia and 60°F)
- $d$  = pipe ID, in.
- $P_1$  and  $P_2$  = pressure at points 1 and 2 respectively, psia
- $L$  = length of pipe, ft
- $S$  = specific gravity of gas at standard conditions
- $T_1$  = temperature of gas at inlet, °R
- $Z$  = compressibility factor of gas (Refer to GPSA Engineering Data Book)

It is important to remember the assumptions used in deriving this equation and when they are appropriate. Short lengths of pipe with high pressure drops are likely to be in turbulent flow (high Reynolds Numbers) and thus the assumptions made by Weymouth are appropriate. Industry experience indicates that the Weymouth equation is suitable for most piping within the production facility. However, the friction factor used by Weymouth is generally too low for large diameter or low velocity lines where the flow regime is more properly characterized by the sloped portion of the Moody diagram.

**2. Panhandle Equation.**

This equation assumes that the friction factor can be represented by a straight line of constant negative slope in the moderate Reynolds number region of the Moody diagram.

The Panhandle equation can be written:

$$Q_g = 0.028E \left[ \frac{P_1^2 - P_2^2}{S^{0.981} Z T_1 L_m} \right]^{0.51} d^{2.53} \quad \text{Eq. 2.11}$$

- $P_1$  = upstream pressure, psia
- $P_2$  = downstream pressure, psia
- $S$  = gas specific gravity
- $Z$  = compressibility factor for gas (Refer to GPSA Engineering Data Book)
- $Q_g$  = gas flow rate, MMscfd (at 14.7 psia, 60°F)
- $T_1$  = flowing temperature, °R
- $L_m$  = length, miles
- $d$  = pipe I.D., inches
- $E$  = efficiency factor
  - = 1.0 for brand new pipe
  - = 0.95 for good operating conditions
  - = 0.92 for average operating conditions
  - = 0.85 for unfavorable operating conditions

In practice, the Panhandle equation is commonly used for large diameter (greater than 10") long pipelines (usually measured in miles rather than feet) where the Reynolds number is on the straight line portion of the Moody diagram. It can be seen that neither the Weymouth nor the Panhandle represent a "conservative" assumption. If the Weymouth formula is assumed, and the flow is a moderate Reynolds number, the friction factor will in reality be higher than assumed (the sloped line portion is higher than the horizontal portion of the Moody curve), and the actual pressure drop will be higher than calculated. If the Panhandle formula is used and the flow is actually in a high Reynolds number, the friction factor will in reality be higher than assumed (the equation assumes the friction factor continues to decline with increased Reynolds number beyond the horizontal portion of the curve), and the actual pressure drop will be higher than calculated.

**3. Spitzglass Equation.**

This equation is used for near-atmospheric pressure lines. It is derived by making the following assumptions in Equation 2.7:

- a.  $f = \left( 1 + \frac{3.6}{d} + 0.03d \right) \left( \frac{1}{100} \right)$
- b.  $T = 520^\circ\text{R}$
- c.  $P_1 = 15 \text{ psi}$
- d.  $Z = 1.0$  for ideal gas
- e.  $\Delta P < 10\%$  of  $P_1$

With these assumptions, and expressing pressure drop in terms of inches of water, the Spitzglass equation can be written:

$$Q_g = 0.09 \left[ \frac{h_w d^5}{S L \left( 1 + \frac{3.6}{d} + 0.03d \right)} \right]^{1/2} \quad \text{Eq. 2.12}$$

where

- $h_w$  = pressure loss, inches of water
- $S$  = gas specific gravity at standard conditions
- $Q_g$  = gas flow rate, MMscfd (at 14.7 psig and 60°F)
- $L$  = length, feet
- $d$  = pipe I.D., inches

c. **Gas Velocity Equation.** Gas velocities may be calculated using the following derived equation:

$$V_g = \frac{60 Z Q_g T}{d_1^2 P} \quad \text{Eq. 2.13}$$

where:

- $V_g$  = gas velocity, feet/second.
- $d_1$  = pipe inside diameter, inches.
- $Q_g$  = gas flow rate, million cubic feet/day (at 14.7 psia and 60°F).
- $T$  = operating temperature, °R
- $P$  = operating pressure, psia
- $Z$  = gas compressibility factor (Refer to GPSA Engineering Data Book)

d. **Compressor Piping.** Reciprocating and centrifugal compressor piping should be sized to minimize pulsation, vibration and noise. The selection of allowable velocities requires an engineering study for each specific application.

e. **General Notes.**

- (1) When using gas flow equations for old pipe, build-up of scale, corrosion, liquids, paraffin, etc., can have a large effect on gas flow efficiency.
- (2) For other empirical equations, refer to the GPSA Engineering Data Book.

2.5 Sizing Criteria for Gas/Liquid Two-Phase Lines.

a. **Erosional Velocity.** Flowlines, production manifolds, process headers and other lines transporting gas and liquid in two-phase flow should be sized primarily on the basis of flow velocity. Experience has shown that loss of wall thickness occurs by a process of erosion/corrosion. This process is accelerated by high fluid velocities, presence of sand, corrosive contaminants such as CO<sub>2</sub> and H<sub>2</sub>S, and fittings which disturb the flow path such as elbows.

The following procedure for establishing an "erosional velocity" can be used where no specific information as to the erosive/corrosive properties of the fluid is available.

- (1) The velocity above which erosion may occur can be determined by the following empirical equation:

$$V_e = \frac{c}{\sqrt{\rho m}} \quad \text{Eq. 2.14}$$

where:

$V_e$  = fluid erosional velocity, feet/second

$c$  = empirical constant

$\rho m$  = gas/liquid mixture density at flowing pressure and temperature, lbs/ft<sup>3</sup>

Industry experience to date indicates that for solids-free fluids values of  $c = 100$  for continuous service and  $c = 125$  for intermittent service are conservative. For solids-free fluids where corrosion is not anticipated or when corrosion is controlled by inhibition or by employing corrosion resistant alloys, values of  $c = 150$  to  $200$  may be used for continuous service; values up to  $250$  have been used successfully for intermittent service. If solids production is anticipated, fluid velocities should be significantly reduced. Different values of "c" may be used where specific application studies have shown them to be appropriate.

Where solids and/or corrosive contaminants are present or where "c" values higher than  $100$  for continuous service are used, periodic surveys to assess pipe wall thickness should be considered. The design of any piping system where solids are anticipated should consider the installation of sand probes, cushion flow tees, and a minimum of three feet of straight piping downstream of choke outlets.

- (2) The density of the gas/liquid mixture may be calculated using the following derived equation:

$$\rho_m = \frac{12409S_1P + 2.7RS_gP}{198.7P + RTZ} \quad \text{Eq. 2.15}$$

where:

$P$  = operating pressure, psia.

$S_1$  = liquid specific gravity (water = 1; use average gravity for hydrocarbon-water mixtures) at standard conditions.

$R$  = gas/liquid ratio, ft<sup>3</sup>/barrel at standard conditions.

$T$  = operating temperature, °R.

$S_g$  = gas specific gravity (air = 1) at standard conditions.

$Z$  = gas compressibility factor, dimensionless.

- (3) Once  $V_e$  is known, the minimum cross-sectional area required to avoid fluid erosion may be determined from the following derived equation:

$$A = \frac{9.35 + \frac{ZRT}{21.25P}}{V_e} \quad \text{Eq. 2.16}$$

where:

$A$  = minimum pipe cross-sectional flow area required, in<sup>2</sup>/1000 barrels liquid per day.

- (4) For average Gulf Coast conditions,  $T = 535^\circ\text{R}$ ,  $S_1 = 0.85$  (35° API gravity oil) and  $S_g = 0.65$ . For these conditions, Figure 2.5 may be used to determine values of  $A$  for essentially sand free production. The minimum required cross-sectional area for two-phase piping may be determined by multiplying  $A$  by the liquid flow rate expressed in thousands of barrels per day.

b. **Minimum Velocity.** If possible, the minimum velocity in two-phase lines should be about  $10$  feet per second to minimize slugging of separation equipment. This is particularly important in long lines with elevation changes.

c. **Pressure Drop.** The pressure drop in a two-phase steel piping system may be estimated using a simplified Darcy equation from the GPSA Engineering Data Book (1981 Revision).

$$\Delta P = \frac{0.000336fW^2}{d_i^5 \rho_m} \quad \text{Eq. 2.17}$$

where:

$\Delta P$  = pressure drop, psi/100 feet.

$d_i$  = pipe inside diameter, inches

$f$  = Moody friction factor, dimensionless.

$\rho_m$  = gas/liquid density at flowing pressure and temperature, lbs/ft<sup>3</sup> (calculate as shown in Equation 2.15).

$W$  = total liquid plus vapor rate, lbs/hr.

The use of this equation should be limited to a  $10\%$  pressure drop due to inaccuracies associated with changes in density.

If the Moody friction factor is assumed to be an average of  $0.015$  this equation becomes:

$$\Delta P = \frac{5 \times 10^{-6} W^2}{d_i^5 \rho_m} \quad \text{Eq. 2.17a}$$

$W$  may be calculated using the following derived equation:

$$W = 3180 Q_g S_g + 14.6 Q_l S_l \quad \text{Eq. 2.18}$$

where:

$Q_g$  = gas flow rate, million cubic feet/day (14.7 psia and 60°F).

$S_g$  = gas specific gravity (air = 1).

$Q_l$  = liquid flow rate, barrels/day.

$S_l$  = liquid specific gravity (water = 1).

*It should be noted this pressure drop calculation is an estimate only.*



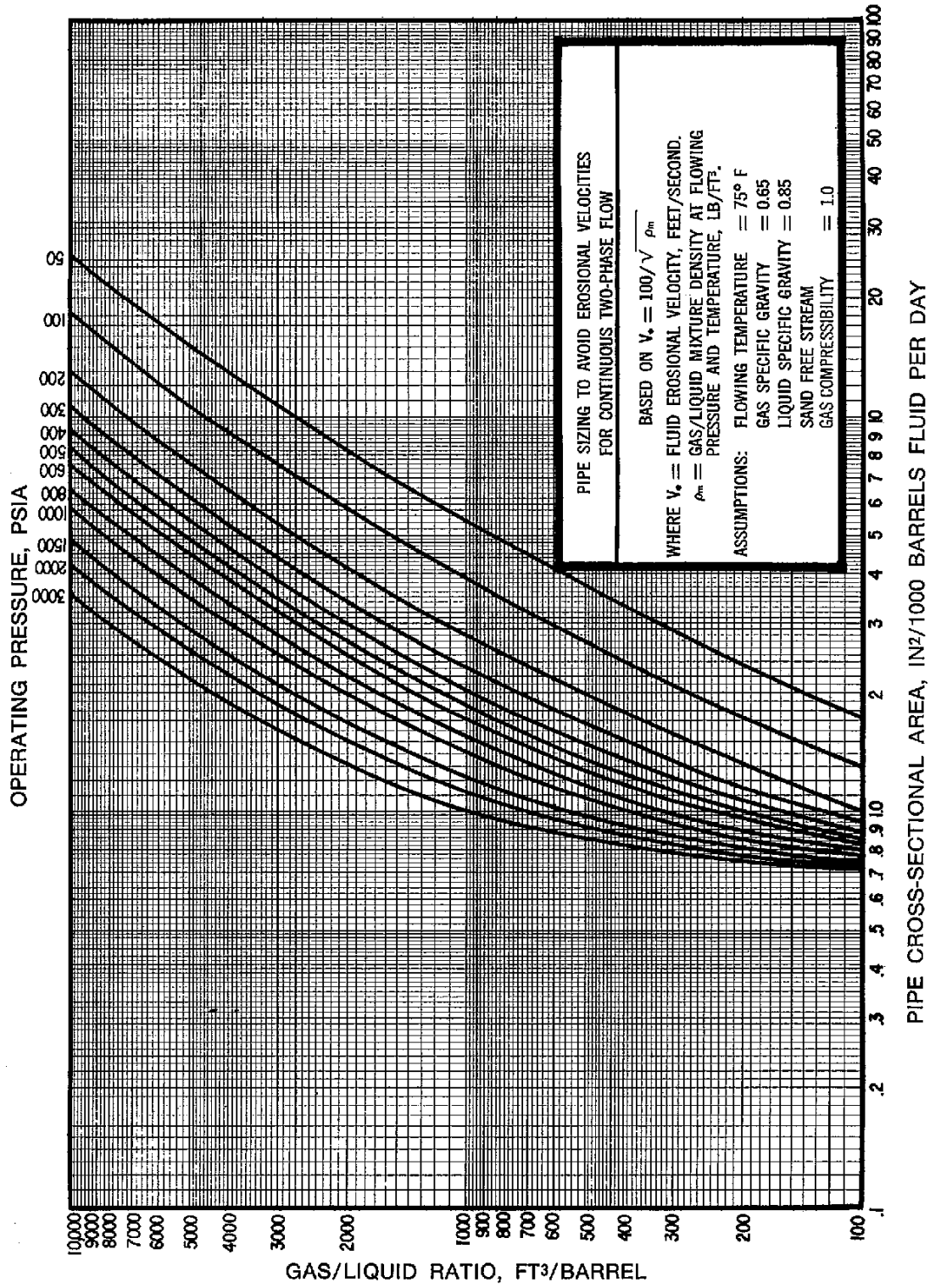

FIGURE 2.5  
 EROSIONAL VELOCITY CHART

**2.6 Pipe Wall Thicknesses.** The pipe wall thickness required for a particular piping service is primarily a function of internal operating pressure and temperature. The standards under which pipe is manufactured permit a variation in wall thickness below nominal wall thickness. It is usually desirable to include a minimum corrosion/mechanical strength allowance of 0.050 inches for carbon steel piping. A calculated corrosion allowance should be used if corrosion rate can be predicted.

- a. The pressure design thickness required for a particular application may be calculated by the following equation from ANSI B31.3:

$$t = \frac{P_i D_o}{2 (SE + P_i Y)} \quad \text{Eq. 2.19}$$

where:

t = pressure design thickness, inches;  
= minimum wall thickness minus corrosion/mechanical strength allowance or thread allowance (See ANSI B31.3)

P<sub>i</sub> = internal design pressure, psig.

D<sub>o</sub> = pipe outside diameter, inches.

E = longitudinal weld joint factor (see ANSI B31.3);

= 1.00 for seamless;

= 0.85 for ERW.

Y = temperature factor (0.4 for ferrous materials at 900°F or below when t < D/6).

S = allowable stress in accordance with ANSI B31.3, psi.

- b. The maximum allowable working pressures for most of the nominal wall thicknesses in sizes 2 inch through 18 inch are given in Table 2.5 for ASTM A106, Grade B, seamless pipe, using a corrosion/mechanical strength allowance of 0.050 inches. The maximum working pressures in Table 2.5 were computed from Equation 2.19, for values of t < D/6. For values of t > D/6, the Lamé equation from ANSI B31.3 was used. Table 2.5 considers internal pressure and temperature only. These wall thicknesses may have to be increased in cases of unusual mechanical or thermal stresses. The maximum allowable working pressure of stainless steel tubing may be calculated using Equation 2.19 with a corrosion/mechanical strength allowance of zero.

- c. Small diameter, thin wall pipe is subject to failure from vibration and/or corrosion. In hydrocarbon service, pipe nipples ¼ inch diameter or smaller should be schedule 160 minimum; all pipe 3 inch diameter or smaller should be schedule 80 minimum. Completely threaded nipples should not be used.

**2.7 Joint Connections.** Commonly accepted methods for making pipe joint connections include butt welded, socket welded, and threaded and coupled. Hydrocarbon piping 2 inch in diameter and larger and pressurized utility piping 3 inch in diameter and larger should be butt welded. All piping 1½ inch or less in diameter should be socket welded for:

- Hydrocarbon service above ANSI 600 Pressure Rating.
- Hydrocarbon service above 200°F.
- Hydrocarbon service subject to vibration.
- Glycol service.

Occasionally, it may not be possible to observe the guidelines given above, particularly when connecting to equipment. In this case, the connection may be threaded or threaded and seal (back) welded. Threads should be tapered, concentric with the pipe, clean cut with no burrs, and conform to API STD 5B or ANSI B2.1. The inside of the pipe on all field cuts should be reamed. Thread compounds should conform to API Bulletin 5A2.

**2.8 Expansion and Flexibility.** Piping systems may be subjected to many diversified loadings. Generally, only stresses caused by (1) pressure, (2) weight of pipe, fittings, and fluid, (3) external loadings, and (4) thermal expansion are significant in the stress analysis of a piping system. Normally, most pipe movement will be due to thermal expansion.

- a. A stress analysis should be made for a two-anchor (fixed points) system if the following approximate criterion from ANSI B31.3-1980 is not satisfied:

$$\frac{D \Delta_1}{(L - U)^2} \leq 0.03 \quad \text{Eq. 2.20}$$

where:

D = nominal pipe size, inches.

Δ<sub>1</sub> = expansion to be absorbed by pipe, inches (See equation 2.21).

U = anchor distance, feet (straight line distance between anchors).

L = actual length of pipe, feet.

Δ<sub>1</sub> may be calculated by the following equation from ANSI B31.3-1980.

$$\Delta_1 = 12LB\Delta T \quad \text{Eq. 2.21}$$

where:

Δ<sub>1</sub> = expansion to be absorbed by pipe, inches.

L = actual length of pipe, feet.

B = mean coefficient of thermal expansion at operating temperatures normally encountered (Approximately 7.0 x 10<sup>-6</sup> inches/inch/°F for carbon steel pipe; for an exact number see ANSI B31.3).

ΔT = temperature change, °F

- b. The following guidelines may help in screening piping or systems that generally will not require stress analysis:

- (1) Systems where the maximum temperature change will not exceed 50°F.
- (2) Piping where the maximum temperature change will not exceed 75°F, provided that the distance between turns in the piping exceeds 12 nominal pipe diameters.

- c. ANSI B31.3-1980 does not require a formal stress analysis in systems which meet one of the following criteria:

- (1) The systems are duplicates of successfully operating installations or replacements of systems with a satisfactory service record.
- (2) The systems can be judged adequate by comparison with previously analyzed systems.

- d. Pipe movement can be handled by expansion bends (including "Loops", "U", "L", and "Z" shaped piping), swivel joints or expansion bellows. Expansion bends are preferred when practical. If expansion bends are not practical, swivel joints should be used. Swivel joints may be subject to leakage and must be properly maintained. Expansion bellows may be subject to failure if improperly installed and should be avoided in pressure piping. Expansion bellows are often used in engine exhaust systems and other low pressure systems.

**2.9 Start-up Provisions.** Temporary start-up cone type screens should be provided in all pump and compressor suction lines. Screens (with the cone pointed upstream) should be located as close as possible to the inlet flanges, with consideration for

later removal. Sometimes a set of breakout flanges are required to remove the screens. The screens should be checked during start-up and removed when sediment is no longer being collected. *Caution should be exercised in screen selection and use to avoid creating NPSH problems.* Consideration should be given to the need for small valves required for hydrostatic test, vent, drain and purge.

#### 2.10 References.

- a. Crane Company, "Flow of Fluids Through Valves, Fittings, and Pipe", Technical Paper No. 410. Copyright 1957.
- b. Hugley, Dale, "Acceleration Effect is Major Factor in Pump Feed System", *Petroleum Equipment and Services*, (January/February 1968).
- c. Hugley, Dale, "Acceleration Head Values are Predictable But—(not from commonly accepted formulae)", *Petroleum Equipment and Services*, (March/April 1968).
- d. Miller, J. E., "Experimental Investigation of Plunger Pump Suction Requirements", Petroleum Mechanical Engineering Conference, Los Angeles, California, September 1964.
- e. Tube Turns Corporation, "Line Expansion and Flexibility", Bulletin TT 809, 1956.
- f. Tuttle, R. N., "Selection of Materials Designed for Use in a Sour Gas Environment", *Materials Protection*, Vol. 9, No. 4 (April 1970).

**TABLE 2.5**  
**MAXIMUM ALLOWABLE WORKING PRESSURES — PLATFORM PIPING**  
**ASTM A106, GRADE B, SEAMLESS PIPE**  
**(STRESS VALUES from ANSI B31.3 — 1980)**

1	2	3	4	5	6	7	8	9	10
Nominal Size In	Outside Diameter In	Nominal Wall Thickness In	Nominal Weight Per Foot Lb	Weight Class	Schedule No.	-20/400°F	401/500°F	501/600°F	601/650°F
2	2.375	0.218	5.02	XS	80	2489	2352	2153	2115
		0.344	7.46	—	160	4618	4364	3994	3925
		0.436	9.03	XXS	—	6285	5939	5436	5342
2½	2.375	0.276	7.66	XS	80	2814	2660	2434	2392
		0.375	10.01	—	160	4194	3963	3628	3565
		0.552	13.70	XXS	—	6850	6473	5925	5822
		0.750	17.02	—	—	9772	9423	8625	8476
3	3.500	0.300	10.25	XS	80	2553	2412	2208	2170
		0.438	14.31	—	160	4123	3896	3566	3504
		0.600	18.58	XXS	—	6090	5755	5268	5176
4	4.500	0.237	10.79	STD	40	1439	1360	1245	1223
		0.337	14.98	XS	80	2276	2151	1969	1934
		0.438	18.98	—	120	3149	2976	2724	2676
		0.531	22.52	—	160	3979	3760	3442	3382
		0.674	27.54	XXS	—	5307	5015	4591	4511
6	6.625	0.280	18.97	STD	40	1206	1139	1043	1025
		0.432	28.57	XS	80	2062	1949	1784	1753
		0.562	36.42	—	120	2817	2663	2437	2395
		0.719	45.34	—	160	3760	3553	3252	3196
		0.864*	53.16	XXS	—	4660	4404	4031	3961
8	8.625	0.277	24.70	—	30	908	858	786	772
		0.322	23.55	STD	40	1093	1038	950	934
		0.406	35.66	—	60	1457	1377	1260	1238
		0.500	43.39	XS	80	1864	1762	1612	1584
		0.594	50.93	—	100	2278	2153	1970	1936
		0.719	60.69	—	120	2838	2682	2455	2413
		0.812*	67.79	—	140	3263	3084	2823	2774
		0.875*	72.42	XXS	—	3555	3359	3075	3022
0.906*	74.71	—	160	3700	3496	3200	3145		
10	10.750	0.250	28.04	—	20	636	601	550	541
		0.279	31.20	—	—	733	693	634	623
		0.307	34.24	—	30	827	781	715	703
		0.365	40.48	STD	40	1023	967	885	869
		0.500	54.74	XS	60	1435	1403	1284	1262
		0.594	64.40	—	80	1811	1712	1567	1540
		0.719	77.00	—	100	2252	2128	1948	1914
		0.844*	89.27	—	120	2700	2552	2336	2295
		1.000*	104.13	XXS	140	3271	3091	2829	2780
		1.125*	115.65	—	160	3737	3531	3232	3176

\*All welds must be stress relieved.

NOTE: Includes Corrosion/Mechanical strength allowance of 0.050 inches and 12½% variation below nominal wall thickness (Manufacturer tolerance).

TABLE 2.5 (Continued)

1	2	3	4	5	6	7	8	9	10		
										MAXIMUM ALLOWABLE WORKING PRESSURES — PSIG	
Nominal Size In	Outside Diameter In	Nominal Wall Thickness In	Nominal Weight Per Foot Lb	Weight Class	Schedule No.	-20/400°F	401/500°F	501/600°F	601/650°F		
12	12.750	0.250	33.38	—	20	535	506	463	455		
		0.330	43.77	—	30	760	719	658	646		
		0.375	49.56	STD	—	—	888	839	768	755	
		0.406	53.56	—	40	976	923	845	830		
		0.500	65.42	XS	—	—	1246	1177	1078	1059	
		0.562	73.22	—	60	1425	1347	1233	1212		
		0.688	88.57	—	80	1794	1695	1552	1525		
		0.844*	107.29	—	100	2258	2133	1953	1919		
		1.000*	125.49	XXS	120	2730	2579	2361	2320		
		1.125*	139.68	—	140	3114	2943	2694	2647		
		1.312*	160.33	—	160	3700	3496	3200	3145		
14	14.000	0.250	36.71	—	10	487	460	421	414		
		0.312	45.68	—	20	645	610	558	549		
		0.375	54.57	STD	30	807	763	698	686		
		0.438	63.37	—	40	971	917	840	825		
		0.500	72.09	XS	—	—	1132	1070	979	962	
		0.594	85.01	—	60	1379	1303	1193	1172		
		0.750	106.13	—	80	1794	1696	1552	1525		
		0.938*	130.79	—	100	2304	2177	1993	1958		
		1.094*	150.76	—	120	2734	2584	2365	2324		
		1.250*	170.22	—	140	3171	2997	2743	2696		
		1.406*	189.15	—	160	3616	3417	3123	3074		
16	16.000	0.250	42.05	—	10	425	402	368	362		
		0.312	52.36	—	20	564	533	488	479		
		0.375	62.58	STD	30	705	666	610	599		
		0.500	82.77	XS	40	988	934	855	840		
		0.656	108.00	—	60	1345	1271	1164	1143		
		0.843*	137.00	—	80	1780	1682	1540	1513		
		1.031*	165.00	—	100	2225	2103	1925	1891		
		1.218*	193.00	—	120	2675	2523	2314	2274		
		1.437*	224.00	—	140	3212	3036	2779	2731		
		18	18.000	0.250	47.39	—	10	378	357	327	321
				0.312	59.03	—	20	501	473	433	425
0.375	70.59			STD	—	—	626	591	541	532	
0.438	82.06			—	30	752	710	650	639		
0.500	93.45			XS	—	—	876	823	753	745	
0.582	105.00			—	40	1001	946	866	851		
0.718	133.00			—	60	1319	1246	1141	1121		
0.937*	171.00			—	80	1771	1674	1532	1506		
1.156*	208.00			—	100	2232	2109	1931	1897		
1.343*	239.00			—	120	2632	2487	2277	2237		

\*All welds must be stress relieved.

## SECTION 3

### SELECTION OF VALVES

**3.1 General.** Ball, gate, plug, butterfly, globe, diaphragm, needle, and check valves have all been used in platform production facilities. Brief discussions of the advantages, disadvantages and design features for each type of valve are given below. Based on these considerations, specific suggestions for the application of certain types of valves are given in the following paragraphs. Valve manufacturers and figure numbers, acceptable to a particular operating company, are normally given by valve type and size in **Pipe, Valves, and Fittings Tables** (See Appendix C). Whenever possible, several different acceptable valves should be listed in the **Pipe, Valves, and Fittings Tables** to provide a choice of valve manufacturers. Valve catalogs contain design features, materials, drawings and photographs of the various valve types.

- a. As a general guideline, lever operated ball valves and plug valves should be provided with manual gear operators as follows:

ANSI 150 lb through 400 lb.....10 inch and larger  
ANSI 600 lb and 900 lb..... 6 inch and larger  
ANSI 1500 lb and higher .....4 inch and larger

- b. As a general guideline the following valves should be equipped with power operators:

- (1) All shutdown valves.
- (2) Centrifugal compressor inlet and discharge valves. These valves should close automatically on shutdown of the prime mover.
- (3) Divert, blowdown and other automatic valves.
- (4) Valves of the following sizes, when frequently operated:
  - ANSI 150 lb .....16 inch and larger
  - ANSI 300 lb and 400 lb .....12 inch and larger
  - ANSI 600 lb and 900 lb .....10 inch and larger
  - ANSI 1500 lb and higher.....8 inch and larger

#### 3.2 Types of Valves.

- a. **Ball Valves.** Ball valves are suitable for most manual on-off hydrocarbon or utilities service when operating temperatures are between -20°F and 180°F. Application of ball valves above 180°F should be carefully considered due to the temperature limitations of the soft sealing material.
- (1) Ball valves are available in both floating ball and trunnion mounted designs. Valves of the floating ball design, develop high operating torques in high pressure services or large diameters but tend to provide a better seal. Trunnion mounted ball valves turn more easily but may not seal as well. Thus, a trade-off decision is required to select the proper type for each application.
  - (2) Ball valves are not suitable for throttling because, in the partially open position, sealing surfaces on the exterior of the ball are exposed to abrasion by process fluids.
  - (3) In critical service, consideration should be given to purchasing ball valves with lubrication fittings for the ball seats, as well as for the stem, since lubrication is sometimes necessary to prevent minor leaks or reduce operating torques. If a double block and bleed capability is desired, a body bleed port independent of the lubrication fittings should be provided.

- b. **Gate Valves.** Gate valves are suitable for most on-off, non-vibrating hydrocarbon or utilities service for all temperature ranges. In vibrating service, gate valves may move open or closed from their normal positions unless the stem packing is carefully adjusted. Gate valves have better torque characteristics than ball or plug valves but do not have the easy operability of quarter turn action.

- (1) In sizes 2 inch and larger, manually operated gate valves should be equipped with flexible discs or expanding gates.
- (2) Gate valves with unprotected rising stems are not recommended since the marine environment can corrode exposed stems and threads, making the valves hard to operate and damaging stem packing.
- (3) Reverse-acting slab gate valves are suitable for automatic shutdown service. With these valves, simple push-pull operators can be used, thus avoiding the complicated levers and cams normally required with ball or plug valves. All moving parts on gate valves with power operators can be enclosed, eliminating fouling by paint or corrosion products.
- (4) Gate valves should not be used for throttling service. Throttling, especially with fluids containing sand, can damage the sealing surfaces.

- c. **Plug Valves.** Plug valves are suitable for the same applications as ball valves (see Section 3.2.a), and are also subject to similar temperature limitations. Plug valves are available with quarter turn action in either lubricated or non-lubricated designs. Lubricated plug valves must be lubricated on a regular schedule to maintain a satisfactory seal and ease of operation. Frequency of lubrication required depends on type of service. The lubrication feature does provide a remedial means for freeing stuck valves. In the non-lubricated design, the seal is accomplished by Teflon, nylon or other "soft" material. They do not require frequent maintenance lubrication but may be more difficult to free after prolonged setting in one position. The application circumstance will generally dictate a selection preference based on these characteristics.

- d. **Butterfly Valves.** Regular Butterfly valves are suitable for *coarse* throttling and other applications where a tight shutoff is not required. It is difficult to accomplish a leak-tight seal with a regular (non-high performance) butterfly valve. They are not suitable as primary block valves for vessels, tanks, etc. Where a tight seal is required, use a high performance valve or limit the valve to low differential pressure and low temperature (150°F) service. Because low torque requirements permit butterfly valves to vibrate open, handles with detents should be specified.

- e. **Globe Valves.** When good throttling control is required (e.g., in bypass service around control valves), globe valves are the most suitable.

- f. **Diaphragm (Bladder) Valves.** In this valve design, a diaphragm made of an elastomer is connected to the valve stem. Closure is accomplished by pressing the diaphragm against a metal weir which is a part of the valve body.

Diaphragm valves are used primarily for low pressure water (200 psig or less) service. They are especially suitable for systems containing appreciable sand or other solids.

- g. **Needle Valves.** Needle valves are basically miniature globe valves. They are frequently used for instrument and pressure gage block valves; for throttling small volumes of instrument air, gas or hydraulic fluids; and for reducing pressure pulsations in instrument lines. The small passageways through needle valves are easily plugged, and this should be considered in their use.
- h. **Check Valves.** Check valves are manufactured in a variety of designs, including swing check, lift plug, ball, piston, and split disc swing check. Of these, a full opening swing check is suitable for most non-pulsating applications. Swing checks can be used in vertical pipe runs (with flow in the upward direction) only if a stop is included to prevent the clapper from opening past top-dead-center. Swing checks should never be used in a downward direction in a vertical piping run. If used where there is pulsating flow or low flow velocities, swing checks will chatter and eventually the sealing surfaces will be damaged. The clapper may be faced with stellite for longer life. To minimize leakage through the seat, a resilient seal should be used. Removable seats are preferred, since they make repair of the valve easier and also facilitate replacement of the resilient seal in the valve body. Swing check valves should be selected with a screwed or bolted bonnet to facilitate inspection or repair of the clapper and seats. In many cases, for a high pressure swing check to be in-line repairable, the minimum size may be two and one half or three inches.
  - (1) Swing check valves in a wafer design (which saves space) are available for installation between flanges. This type of check valve is normally not full opening, and requires removal from the line for repair.
  - (2) The split disc swing check valve is a variation of the swing check design. The springs used to effect closure may be subject to rapid failure due to erosion or corrosion.
  - (3) Lift plug check valves should only be used in small, high pressure lines, handling clean fluids. Lift plug valves can be designed for use in either horizontal or vertical lines, but the two are not interchangeable. Since lift plug valves usually depend on gravity for operation, they may be subject to fouling by paraffin or debris.
  - (4) Ball check valves are very similar to lift plug check valves. Since the ball is lifted by fluid pressure, this type check valve does not have a tendency to slam as does a swing check valve. It is therefore preferable in sizes 2 inch or smaller for clean services that have frequent flow reversals.
  - (5) Piston check valves are recommended for pulsating flow, such as reciprocating compressor or pump discharge lines. They are not recommended for sandy or dirty fluid service. Piston check valves are equipped with an orifice to control the rate of movement of the piston. Orifices used for liquid services are considerably larger than orifices for gas services. A piston check valve designed for gas service should not be used

in liquid service unless the orifice in the piston is changed.

**3.3 Valve Sizing.** In general, valves should correspond to the size of the piping in which the valves are installed. Unless special considerations require a full opening valve (sphere launching or receiving, minimum pressure drop required, meter proving, pump suction, etc.), regular port valves are acceptable.

- a. The pressure drop across a valve in liquid service may be calculated from the following (Fluid Controls Institute) equation:

$$\Delta p = S_1 \left( \frac{\text{GPM}}{C_v} \right)^2 \quad \text{Eq. 3.1}$$

where:

$\Delta p$  = pressure drop, psi.

GPM = liquid flow rate, gallons/minute.

$C_v$  = valve coefficient (GPM water flow, at 60°F, across valve with a pressure drop of 1 psi).

$S_1$  = liquid specific gravity (water = 1).

- b. For a valve in gas service, the following (Fluid Controls Institute) equation may be used:

$$\Delta p = 941 \left( \frac{Q_g}{C_v} \right)^2 \frac{S_g T}{P} \quad \text{Eq. 3.2}$$

where:

$\Delta p$  = pressure drop, psi.

$S_g$  = gas specific gravity (air = 1).

T = flowing temperature, °R.

P = flowing pressure, psia.

$Q_g$  = gas flow rate, million cubic feet/day (14.7 psia and 60°F).

$C_v$  = valve coefficient (GPM water flow, at 60°F, across valve with a pressure drop of 1 psi).

- c. Values of  $C_v$  are usually published in valve catalogs. In calculating the overall pressure drop in a piping system, it is common practice to add the equivalent length of valves to the length of straight pipe. Valve manufacturers usually publish data on their valves, either directly in terms of Equivalent Length of Straight Pipe in Feet, or as length/diameter ratios. If such data are not available for a particular valve, approximate values may be read from Table 2.2. Block valves and bypass valves, used in conjunction with control valves, should be sized in accordance with API RP 550.

**3.4 Valve Pressure and Temperature Ratings.** Steel valves are manufactured in accordance with API Std 600, API Std 602, API Spec 6A, API Spec 6D or ANSI B16.5-1981. The API specifications cover complete manufacturing details, while ANSI B16.5-1981 covers pressure-temperature ratings and dimensional details.

- a. Most steel valves used in platform facilities are designated ANSI and are designed to the pressure-temperature ratings for steel pipe flanges and flanged fittings given in ANSI B16.5. Face-to-face and end-to-end dimensions for steel valves are covered in ANSI B16.10. The allowable working pressure for an ANSI B16.5-1981, an API 600, an API 602 or an API 6D valve is a function of the operating temperature.

- b. Steel valves built to API Spec 6A are used primarily on wellheads and flowlines. API 6A valves are designated API 2000, 3000, 5000, 10,000, 15,000 and 20,000. The API 6A designation numerically denotes the allowable working pressure for temperature between -20°F and 250°F. It should be cautioned that although API 6A and ANSI B16.5 flanges are similar dimensionally, they are fabricated from different materials and consequently have different pressure ratings, corrosion resistance and weldability.
- c. Cast iron valves are designed in accordance with ANSI B16.1 and, in sizes 2 inch through 12 inch, are rated for either 125 psi saturated steam or 200 psi cold water (nonshock). Steel valves are recommended for hydrocarbon service.
- d. The allowable working pressures and temperatures described above consider the metal valve parts only. For valves utilizing resilient sealing materials, the maximum allowable operating temperature is normally limited by the resilient material. The maximum permissible temperatures for valves are indicated in valve catalogs and should be included in the Pipe, Valves, and Fittings Tables described in Appendix C.

### 3.5 Valve Materials.

#### a. Non-Corrosive Service.

- (1) For non-corrosive services, carbon steel meeting the requirements of API 600, API 6A, API 6D, or ANSI B16.5-1981 is satisfactory for valve bodies because of its strength, ductility and resistance to damage by fire.
- (2) Cast or ductile iron valve bodies should not be used for hydrocarbon or glycol services because of their low impact properties. Non-ferrous valves are not suitable for process hydrocarbon service because they may fail in a fire; they may be suitable for instrument and control system service. Cast iron, ductile iron, and bronze body valves may be used for water services.
- (3) One-half inch and smaller needle valves for process hydrocarbon service should be austenitic stainless steel, such as AISI 316 or

AISI 316L, for corrosion resistance and ease of operation.

- (4) Resilient sealing materials used in valves include Buna N, Neoprene, Delrin, Viton, Teflon, Nylon and tetrafluoroethylene (TFE). Resilient sealing materials should be carefully selected to be compatible with the process fluids and temperatures.

#### b. Corrosive Service.

- (1) Generally, carbon steel valve bodies with corrosion resistant internal trim are used for corrosive service. AISI 410 type stainless steel is generally used for internal trim. Austenitic stainless steels, such as AISI 316 and higher alloys may also be used for internal trim.
  - (2) For low-pressure (200 psig or lower) salt water services, butterfly valves with ductile iron body, aluminum-bronze disc, and AISI 316 stainless steel stem with Buna N seals are satisfactory. Gate valves in this service should be iron body bronze trim (IBBM). For high pressure (above 200 psig) salt water applications, steel gate valves with aluminum-bronze trim give good service.
- c. **Chloride Stress Cracking Service.** Consideration should be given to chloride stress cracking when selecting trim materials, see Paragraph 1.7.d.
- d. **Sulfide Stress Cracking Service.** Valve bodies and internal trim should be in accordance with NACE MR-01-75 or constructed of materials which can be demonstrated to be resistant to sulfide stress cracking in the environment for which it is proposed.

#### 3.6 References.

- a. Cameron Hydraulic Data Handbook, Ingersoll-Rand Company.
- b. Chemical Engineering-Deskbook Issue, "Valves", October 11, 1971.
- c. Evans, Frank L., "Special Report on Valves", *Hydrocarbon Processing*, Vol. 40, No. 7 (July 1961).
- d. Fluid Controls Institute, Bulletin FCI 62-1.



## SECTION 4

### FITTINGS AND FLANGES

**4.1 General.** Welded, screwed and flanged piping connections are all acceptable for use in platform piping within the application limitations discussed in the following sections. Only carbon steel materials are discussed since carbon steel is suitable for the preponderance of platform piping systems. The operator should select other materials, if needed, on an engineering basis (See Section 1.1).

- a. Many of the fittings and flanges described in this section are manufactured using materials in accordance with ASTM A105. In general, ASTM A105 does not require heat treatment (normalizing) for piping components (flanges, fittings and similar parts) 4 inch nominal pipe size and smaller, except for ANSI flanges above 300 lb primary service rating.
- b. Fittings and flanges that do not require normalizing in accordance with ASTM A105 due to size or pressure rating, should be normalized when used for service temperatures below 30°F. Fittings and flanges in this category should be marked HT, N, <sup>\*</sup>, or with some other appropriate marking to designate normalizing.

**4.2 Welded Fittings.** Material for butt weld fittings should be seamless ASTM A234, Grade WPB. These fittings are made of carbon steel and are intended for use with Grade B pipe. Unless the purchaser clearly specifies that the fittings shall be seamless, fittings with welded seams may be furnished at the manufacturer's option.

- a. Dimensions and tolerances for butt weld, long-radius elbows and tees are covered by ANSI B16.9. Short radius butt weld elbows are covered by ANSI B16.28. If space permits, long radius elbows should be used in platform piping systems. Short radius elbows are subject to high stress concentrations in the throat of the sharp curvature bend, and should be derated to 80 percent of the calculated allowable working pressure if subject to pulsation or vibration.
- b. ANSI B16.9 requires that the pressure rating of steel butt weld fittings be equal to that of seamless pipe of the same wall thickness. Butt weld fittings should, therefore, be purchased with a wall thickness to match the pipe to which they will be connected, except when thicker walls are required for short radius elbows which have been derated as outlined above. Otherwise, the pressure rating of the system will be limited by the lesser wall thickness in the fittings. If it is necessary to weld fittings or pipe with unequal wall thicknesses, the procedure outlined in Appendix B of this RP should be used to design the joint.
- c. Socket welding elbows and tees are manufactured in accordance with ANSI B16.11. Normally, ASTM A105 steel forgings are used. Bar stock meeting the requirements of ANSI B16.11 may also be used. It should be required that fittings machined from bar stock may not have the forging flow lines parallel with the axis of the fittings. Socket welding fittings are supplied in pressure class designations of 3000, 6000, and 9000 lb non-shock WOG (water, oil, gas).
- d. The pressure drop due to welded fittings may be calculated by including their equivalent length in the total length of the piping system. Equivalent lengths for welded elbows and tees are included in Table 2.2.

**4.3 Screwed Fittings.** When screwed fittings are permitted by Section 2.7, forged steel screwed fittings should be used for both hydrocarbon and utility service to reduce the possibility of accidental misapplication. Forged steel screwed fittings are normally manufactured of ASTM A105 steel in 2000, 3000, and 6000 lb ratings to ANSI B16.11.

#### 4.4 Branch Connections.

- a. Branch connections in welded lines should be butt weld straight tees or reducing tees when the branch line is 2 inch nominal pipe size or larger, and is equal to or greater than one half of the nominal run size. If the branch line is 2 inch nominal pipe size or larger, but less than one half of the nominal run size, welded nozzles<sup>1</sup> may be used. Branch lines 1½ inch nominal pipe size and smaller should be connected to runs 1½ inch nominal and smaller, with socketweld tees, and to runs 2 inch nominal and larger with socketweld couplings or equivalent. Table 4.1 illustrates the provision of the paragraph.
- b. Stub-in connections should generally not be used (See Paragraph 4.9, Reference c). The disadvantages of an unreinforced stub-in connection are numerous. Sharp changes in section and direction at the junction introduce severe stress intensifications. Reinforcement using a pad or a saddle improves the situation somewhat; however, the finished connection is difficult to examine for welding and other defects. The likelihood that stress-intensifying defects will escape detection make stub-ins a poor choice for critical services or those with severe cyclic operating conditions or loadings. If stub-in connections are necessary, the use of full encirclement saddles is recommended.
- c. Branch connections in screwed piping systems should be made using straight tees and swage reducers, or reduced outlet tees. All screwed piping systems should be isolated from welded piping systems by block valves.

#### 4.5 Flanges.

- a. **General.** Welding neck flanges should be used for piping 2 inch and larger. Slip-on flanges are not generally recommended. ANSI type flanges, manufactured in conformance with ANSI B16.5, are used in most applications. API type flanges, manufactured according to API Spec 6A, are used primarily near the wellhead.

(1) ANSI flanges are supplied in raised face (RF) and ring-type joint (RTJ). RF flanges offer increased ease of maintenance and equipment replacement over RTJ. RTJ flanges are commonly used in higher pressure service of ANSI 900 and above and may also be used for ANSI 600 in piping systems subject to vibrating service. RTJ flanges should also be considered for services with special temperature or hazard problems. When RTJ flanges are used, the piping configuration should be designed to allow component removal since additional flexibility is required to remove the ring gasket. Materials for ANSI flanges are normally manufactured in accordance with ASTM A-105. Flanges manufactured in accordance with ASTM A-181 may be suitable for certain non-critical services, e.g., water or atmospheric drains.

<sup>1</sup>ASME Sect. VIII, Div. I, Part UW

**TABLE 4.1  
BRANCH CONNECTION SCHEDULE—WELDED PIPING**

1 NOMINAL BRANCH SIZE (inches)	2 NOMINAL RUN SIZE (inches)															
	3 1/2	4 3/4	5 1	6 1 1/2	7 2	8 2 1/2	9 3	10 4	11 6	12 8	13 10	14 12	15 14	16 16	17 18	
1/2	SWT	SWT	SWT	SWT	6SC	6SC	6SC	6SC	6SC	6SC	6SC	6SC	6SC	6SC	6SC	6SC
3/4		SWT	SWT	SWT	SOL	6SC	6SC	6SC	6SC	6SC	6SC	6SC	6SC	6SC	6SC	6SC
1			SWT	SWT	SOL	SOL	SOL	6SC	6SC	6SC	6SC	6SC	6SC	6SC	6SC	6SC
1 1/2				SWT	TR	SOL	SOL	SOL	6SC	6SC	6SC	6SC	6SC	6SC	6SC	6SC
2					T	RT	RT	RT	WOL	WOL	WOL	WOL	WOL	WOL	WOL	WOL
2 1/2						T	RT	RT	WOL	WOL	WOL	WOL	WOL	WOL	WOL	WOL
3							T	RT	RT	WOL	WOL	WOL	WOL	WOL	WOL	WOL
4								T	RT	WOL	WOL	WOL	WOL	WOL	WOL	WOL
6									T	RT	RT	RT	WOL	WOL	WOL	WOL
8										T	RT	RT	RT	RT	WOL	WOL
10											T	RT	RT	RT	RT	RT
12												T	RT	RT	RT	RT
14													T	RT	RT	RT
16														T	RT	RT
18															T	RT

**Legend**

- T—Straight Tee (Butt Weld)
- RT—Reducing Tee (Butt Weld)
- TR—Straight Tee and Reducer or Reducing Tee
- WOL—Welded nozzle or equivalent (Schedule of Branch Pipe)
- SOL—Socketweld couplings or equivalent—6000# Forged Steel
- SWT—Socketweld Tee
- 6SC—6000# Forged Steel Socketweld Coupling (3/4 inch and smaller threadbolts or screwed couplings may be used for sample, gage, test connection and instrumentation purposes)

(2) Materials for API flanges are specified in API Spec 6A. Some API material types require special welding procedures. API flanges are available in 2000, 3000, 5000, 10,000, 15,000 and 20,000 psi pressure ratings. The maximum working pressure ratings are applicable for temperatures between -20°F and 250°F. API flanges rated 2000, 3000 and 5000 psi are designated API Type 6B, and require Type R or RX gaskets; 10,000, 15,000, and 20,000 psi ratings are designated API Type 6BX and require BX ring gaskets. API Type 6B flanges should have a full-face contour. API Type 6BX flanges should have a relieved-face contour.

**b. Gaskets.**

(1) For ANSI raised face (RF) flanges, spiral-wound asbestos gaskets with stainless steel windings should be used because of their strength and sealing ability. For flat face ductile or cast iron valves used in water service, full face compressed asbestos gaskets or arimid or glass reinforced elastomer bound gaskets should be used. If less than full face gaskets are used on flat faces, flanges may be broken as flange bolts are tightened. If gaskets containing asbestos are unavailable or cannot be used in a particular service, other gasket materials are available. Flexible graphite sheet laminated with stainless steel reinforcement and graphite filled spiral wound gaskets are an acceptable alternate for asbestos for hydro-

carbon and steam services. Use of graphite or other asbestos substitutes for other services should be preceded by service-specific studies.

- (2) Ring gaskets for API and ANSI RTJ flanges are manufactured in accordance with API Spec 6A. API ring-joint gaskets are made of either soft iron, low-carbon steel, AISI 304 stainless steel or AISI 316 stainless steel. Unless otherwise specified by the purchaser, ring-joint gaskets made of soft iron or low-carbon steel are cadmium-plated. For ANSI and API Type 6B RTJ flanges, either API Type R or RX gaskets are required. Type R ring-joint gaskets are made in either an octagonal or oval cross-section. Type RX ring-joint gaskets are pressure energized and have a modified octagonal cross-section. Type R and RX gaskets are interchangeable; however, RX gaskets have a greater ring height so the distance between made-up flanges is greater and longer flange bolts are required.
- (3) Type R ring-joint gaskets of soft iron should be used in ANSI 600 lb and 900 lb services. Type RX ring-joint gaskets of low-carbon steel provide a better seal at high pressure and should be used in ANSI 1500 lb and higher and in API 2000, 3000 and 5000 lb services.
- (4) API Type 6BX flanges require API Type BX pressure energized ring gaskets. These

gaskets, made of low-carbon steel, should be used for API 10,000, 15,000 and 20,000 lb flanges.

**c. Flange Protectors.** Various methods (painting, wrapping with tape, etc.) have been tried to protect gaskets, bolts and flange faces from corrosion; none have been completely satisfactory. Potential solutions include: (1) the use of soft rubber flange protectors (300°F limit) which are installed when the flange is made up; and (2) stainless steel or polymer bands with a grease fitting. For H<sub>2</sub>S service, the bolts should be left open to allow the wind to disperse any seepage.

**d. Bolts and Nuts.** For flanged piping systems, stud bolts, threaded over their length in accordance with ASTM A193, Grade B7, or ASTM A354, Grade BC, should be used. Nuts should be heavy hexagon, semi-finished, in accordance with ASTM A194, Grade 2H. Bolts and nuts should be protected from corrosion; current methods include cadmium plating, hot-dip galvanizing, and resin coatings.

**4.6 Proprietary Connectors.** Several proprietary connectors are available to replace flanges. Such connectors are satisfactory if they have sealing, strength and fire resistant qualities comparable to flanges. Specially machined hubs and ring gaskets are required on valves and fittings to mate with the connectors. Alignment is critical.

**4.7 Special Requirements for Sulfide Stress Cracking Service.** Fitting and flange materials, as normally manufactured, are generally satisfactory for sulfide stress cracking service with the additional stipulation that they be modified to conform to the requirements of NACE MR-01-75. ASTM A194, Grade 2M, nuts and ASTM A193, Grade B7M, bolts are generally satisfactory for pipe flanges. Consideration should also be given to torque requirements during installation. Type R and RX rings should be made of annealed AISI 316 stainless steel.

**4.8 Erosion Prevention.** To minimize erosion where sand production is expected, short radius pipe ells should not be used. All turns in flowlines should be made with tees and weld caps (or blind flanges), cap tees or flow tees, or long radius bends (minimum bending radius should be in accordance with ANSI B31.3). For a discussion of maximum velocities to minimize erosion, see Paragraph 2.5.a.

#### 4.9 References.

- a. Assini, John, "Welded Fittings and Flanges", *Southern Engineering* (October 1969).
- b. Canham, W. G., and Hagerman, J. R., "Reduce Piping Connection Costs", *Hydrocarbon Processing* (May 1970).
- c. Tube Turns Division of Chemetron Corporation, *Piping Engineering Handbook* (October 1969).

## SECTION 5

## DESIGN CONSIDERATIONS FOR PARTICULAR PIPING SYSTEMS

**5.1 General.** This section presents considerations for flow schemes, piping layouts, and specific design requirements for particular piping systems.

**5.2 Wellhead Accessory Items.**

**a. Sampling and Injection Connections.** Connections may be desired near the wellhead for chemical injection and for obtaining samples (See Figures 5.1A and 5.1B). If installed, they should be ½ inch minimum nominal size and include a close-coupled block valve. Associated piping should be stainless steel tubing or heavy wall pipe and should be well protected to minimize the possibility of damage. A spring loaded ball check valve should be close-coupled to the block valve on injection lines.

**b. Chokes.** Chokes are normally installed to control the flow from oil and gas wells. Choke types include adjustable, positive and combination. The number and location of chokes depend on the amount of pressure drop taken, well fluid, flow rate, and solids in the wellstream. Usually, if only one choke is used, it should be located near the wellhead. Additional chokes may be located near the manifold, entering low temperature separation units, in conjunction with line heaters, etc. The following general guidelines should be considered regardless of the number of chokes or their location:

- (1) Choke bodies should be installed in a manner that will permit easy removal and trim changes.
- (2) The downstream flow passage within ten nominal pipe diameters should be free of abrupt changes in direction to minimize flow cutting due to high velocity.
- (3) Outlet connections should be examined to determine if their bore should be tapered to improve flow patterns.
- (4) Suitable provisions should be provided to isolate and depressure the choke body when changing trim, removing trash, etc.

**5.3 Flowline and Flowline Accessories.** When designing flowlines, consideration should be given to pressure, temperature, velocity, erosive and corrosive effects on the pipe, etc. (See Sections 2, 3 and 4). The accessories discussed below may be used as necessary.

- a. Flowline Pressure Sensor.** The installation of a flowline sensor should be in accordance with API RP 14C. Further, the connection should be ½ inch minimum nominal size and located to minimize the possibility of plugging and freezing. Connections on the bottom of the line or in turns should be avoided. Sensors should be installed with an external test connection and block valve. Sensing lines should be stainless steel and secured to prevent whip in case of severance.
- b. Flowline Orifice Fitting.** A flowline orifice fitting, as shown on Figures 5.1A and 5.1B, may be desirable in gas well service for either a well monitoring aid or as a means of production allocation.
- c. Flowline Heat Exchanger.** If a flowline heat exchanger is used (See Figures 5.1A and 5.1B),

the following provisions should be considered:

- (1) Connections should be arranged so the exchanger bundle may be pulled without having to cut or weld on inlet and outlet piping.
- (2) On the flanged end of the shell, exchanger U-bends, if used, should either be exposed to the exterior, or easily accessible for nondestructive testing.
- (3) A flanged end heat exchanger shell of a standard dimension is desirable so bundles can be interchanged, or pulled and repaired.
- (4) A relief system in accordance with Section 5.8 should be provided.

**d. Flowline Check Valve.** A flowline check valve should be installed to minimize back flow due to inadvertent switching of a low pressure well into a higher pressure system, or in case of line rupture. Provisions should be made for blowdown of the flowline segment between wellhead and check valve to facilitate periodic testing at check valve. See Section 3.2.h for a discussion of check valves.

**e. Flowline Support.** Flowlines should be supported and secured to minimize vibration and to prevent whip. See Section 6.4 for discussion of piping supports. When designing flowline supports, it should be recognized that even though the wellhead may be fixed to the platform, there is a possibility of independent wellhead movement due to wave action, wind forces, etc., on the conductor.

**5.4 Production Manifolds.**

**a. General.** For illustration purposes, Figures 5.1A and 5.1B show a six-header manifold. The actual number and function of headers depend upon the specific application. The pipe routing to the production headers should be the shortest and least tortuous. Each part of the manifold should be designed to limit maximum velocity in accordance with Section 2.5.a. Fabricated components should be stress relieved, if required, in accordance with ANSI B31.3. Provisions should be made to allow non-destructive testing of headers. Quarter turn valves are preferred in manifold service for ease of operation. Above 6000 psig working pressure, only gate valves are generally available.

**b. Manifold Branch Connections.** Manifold branch connections should be in accordance with Table 4.1. If Weldolets® are used, care should be taken to ensure the entrance hole is smooth and free of burrs after it is welded in place. The terminus of the manifold runs should be blind flanged to provide a fluid cushion area and for possible future expansion.

**c. Manifold Valve Installation.** The manifold arrangement should provide easy access to each valve for operational purposes and easy removal. In initial design of the manifold, it may be desirable to make provisions for the future installation of valve operators.

**5.5 Process Vessel Piping.** A typical three-phase process vessel with standard accessories and many optional items is shown on Figure 5.2. Different vessels are required for different functions in processing;

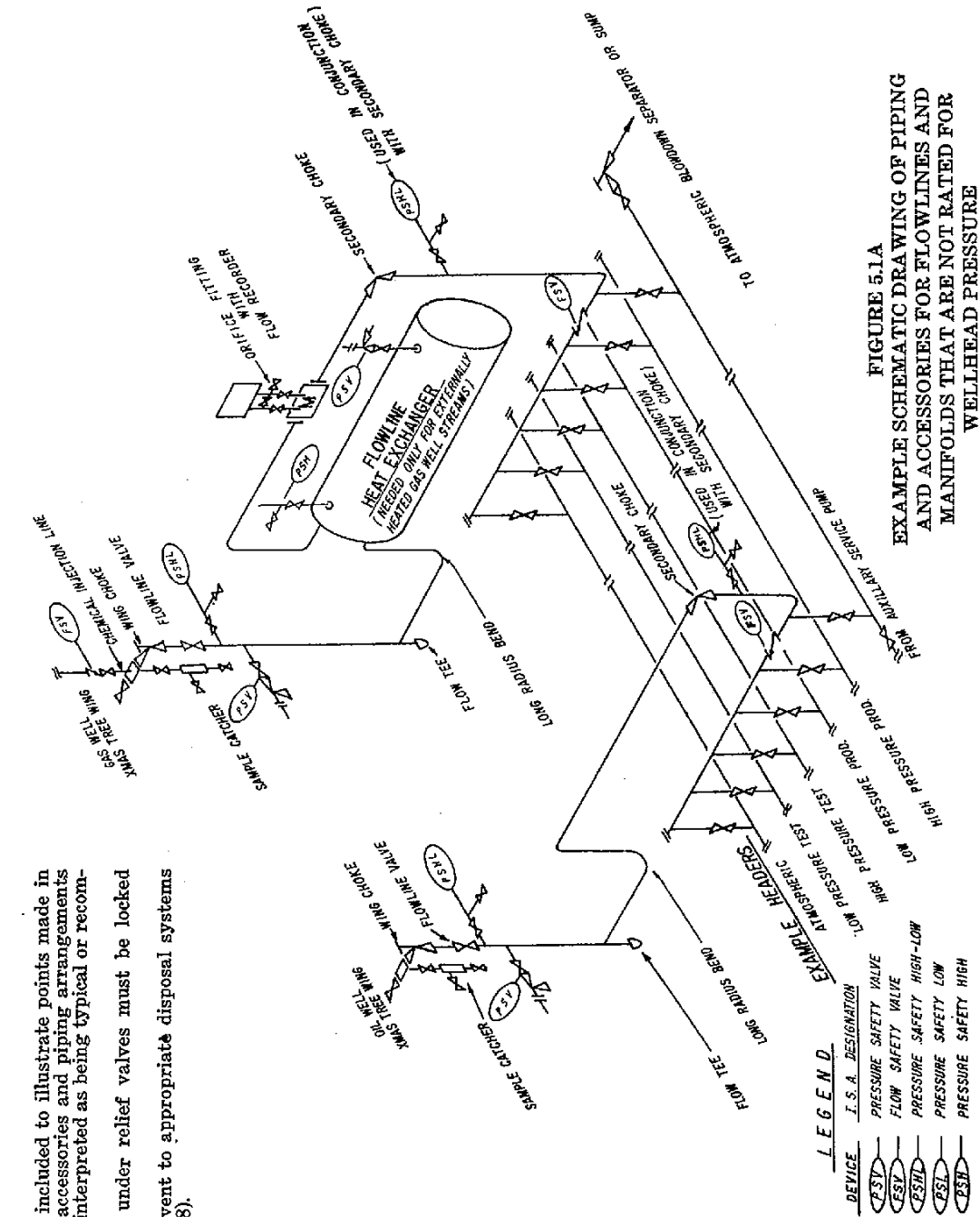

**FIGURE 5.1A**  
**EXAMPLE SCHEMATIC DRAWING OF PIPING**  
**AND ACCESSORIES FOR FLOWLINES AND**  
**MANIFOLDS THAT ARE NOT RATED FOR**  
**WELLHEAD PRESSURE**

**NOTES:**

1. This figure is included to illustrate points made in the text. The accessories and piping arrangements should not be interpreted as being typical or recommended.
2. Block valves under relief valves must be locked open.
3. Relief valves vent to appropriate disposal systems (See Section 5.8).

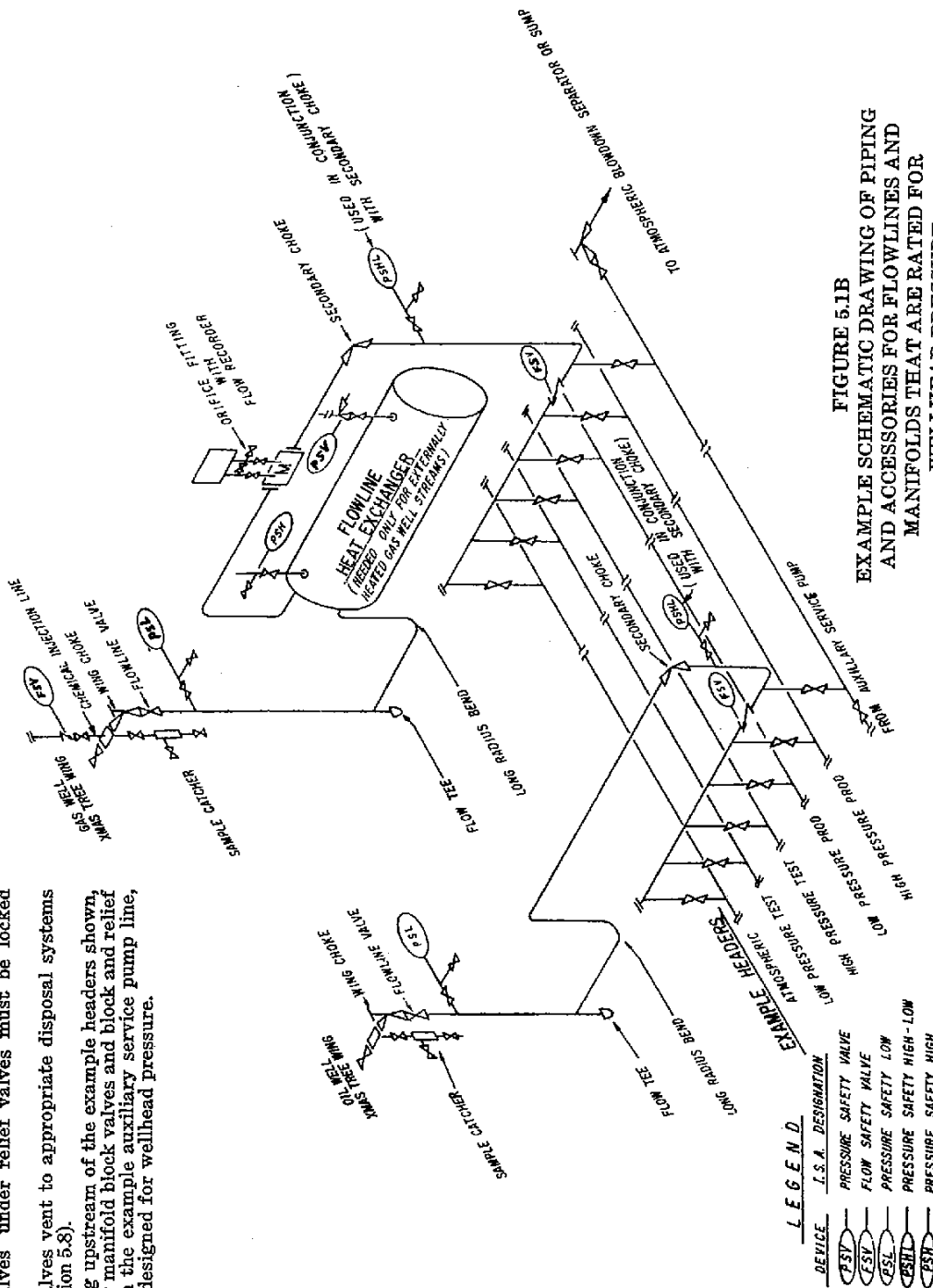

FIGURE 5.1B  
EXAMPLE SCHEMATIC DRAWING OF PIPING AND ACCESSORIES FOR FLOWLINES AND MANIFOLDS THAT ARE RATED FOR WELLHEAD PRESSURE

NOTES:

1. This figure is included to illustrate points made in the text. The accessories and piping arrangements should not be interpreted as being typical or recommended.
2. Block valves under relief valves must be locked open.
3. Relief valves vent to appropriate disposal systems (See Section 5.8).
4. All piping upstream of the example headers shown, including manifold block valves and block and relief valves on the example auxiliary service pump line, must be designed for wellhead pressure.

however, all of the flow streams to and from a vessel are generally handled in a similar manner. All of the items shown in Figure 5.2 may not be needed, but are shown in their recommended location when required. Accessories should be installed to permit ready removal for repairs or replacement. Safety devices should be capable of being tested in place.

**5.6 Utility Systems.** This section deals with pneumatic, fire water, potable water, sewage and related systems.

**a. Pneumatic Systems.** Pneumatic systems are required to provide a dependable supply for pneumatically operated components. All pipe, tubing and fittings  $\frac{1}{2}$  inch nominal size and smaller should be AISI 316 or 316L stainless steel, with 0.035 inch minimum wall thickness where exposed to the atmosphere. Synthetic tubing may be used in weatherproof enclosures or in fire loop safety systems (See Section 2.1.e). Fire loop safety systems should be in accordance with API RP 14C. Piping should be installed in a manner that will minimize low points or traps for liquid. Outlets from vessels and piping should be from the top of the system and drains from the bottom. Blowdown provisions should be included in the piping system to allow removal of condensation. Pneumatic systems should be tested in accordance with Section 7.4.c.

- (1) **Air Systems.** Main air headers should utilize corrosion resistant material such as threaded and coupled galvanized steel. Piping drops to instruments should be in accordance with Paragraph 5.6.a. Care must be exercised in locating air compressor suction to preclude the introduction of gas or hydrocarbon vapors into the system. No cross-overs, whereby air and gas could be intermixed, should be allowed anywhere in the system.
- (2) **Gas Systems.** For gas systems, vents and relief valves should be piped to a safe location if it is determined that the volumes capable of being vented could create an abnormal condition. The gas source chosen should be the driest gas available on the platform. The following guidelines may be helpful in designing an instrument gas (or a fuel gas) system:
  - (a) Consideration should be given to the necessity of dehydrating the gas prior to taking a significant pressure drop. An external heat source may be required to prevent freezing if the gas is not dehydrated.
  - (b) The gas should be expanded into a separator to prevent hydrates and liquids from entering the system piping.
  - (c) The inlet and outlet pressure rating of pressure reduction devices should be carefully considered. If the outlet pressure rating is less than the inlet source pressure, a relief device should be close-coupled to the reduction device.
  - (d) Parallel reduction devices should be considered to maintain system operation in the event the primary device fails.

**b. Fire Water Systems.** Fire water systems are normally constructed of carbon steel pipe in accordance with Sections 2, 3 and 4. Special corrosion resistant materials may be desirable. The fire water system may require sectionalizing valves such that if one portion of the system is inoperable, it can be closed off, and the remainder of the system could remain in service. Accessibility during a fire should be considered when locating fire hose stations and/or turrets. In the determination of required flow rates, consideration should be given to the surface area, location of the equipment and to the maximum number of discharge nozzles which could be in use simultaneously (See NFPA, National Fire Code, Volumes 6 and 8; API RP 14G).

**c. Potable Water Systems.** Threaded and coupled galvanized steel pipe, and bronze valves should generally be used in potable water service. Copper pipe may be used within the confines of buildings. Toxic joint compounds should be avoided. If water makers are used, consideration should be given to potential contamination of the water from heating sources. When potable water is supplied to other facilities such as engine jacket water makeup, etc., care should be exercised to prevent contamination from backflow.

**d. Sewage Systems.** Interior sewage piping, such as in living quarters areas, should be carbon steel, cast iron pipe with babbitt, or lead sealed joints or non-metallic pipe properly supported per ANSI B31.3. Exterior piping may be carbon steel, cast iron, or non-metallic (when properly supported and protected from sunlight). All piping should be well supported and have a minimum slope of  $\frac{1}{8}$  inch per foot. The system should be designed with adequate clean-out provisions. Discharge lines from sewage treatment plants should terminate near water level and contain readily accessible sampling connections. Care should be exercised in locating vents.

**5.7 Heating Fluid and Glycol Systems.** The paramount safety consideration in the design of heating fluid systems is containment of the fluid for personnel protection and fire prevention. All piping, valves and fittings should be in accordance with Sections 2, 3, and 4 except that flanges for other than low pressure steam and hot water systems should be a minimum of ANSI 300 lb to minimize leakage. Piping should be designed for thermal expansion (See Section 2.8). Thermal insulation should be in accordance with Section 6.6.

- a. If the process side of a shell and tube heat exchanger has a higher operating pressure than the design pressure of the heating fluid side, the heating fluid side must be protected by a relief device. The location of the relief device depends on the actual design of the system. If possible, the relief device should be located on the expansion (surge) tank which will serve as a separator. All heating fluid should pass through expansion (surge) tank to allow venting of any gas present. A relief device may also be required at the heat exchanger. Consideration should also be given to tube failure in heat exchangers where the operating pressure of the heating fluid system exceeds the test pressure of the process system.
- b. The effect of mixing hot fluids with cold fluids (see API RP 521, Section 37) should be considered when determining how to dispose of the discharge of a relief device on a heat

**NOTES:**

1. This figure is included to illustrate points made in the text. The accessories and piping arrangements should not be interpreted as being typical or recommended.
2. Block valves under relief valves must be locked open.
3. Relief valves vent to appropriate disposal systems (See Section 5.8).

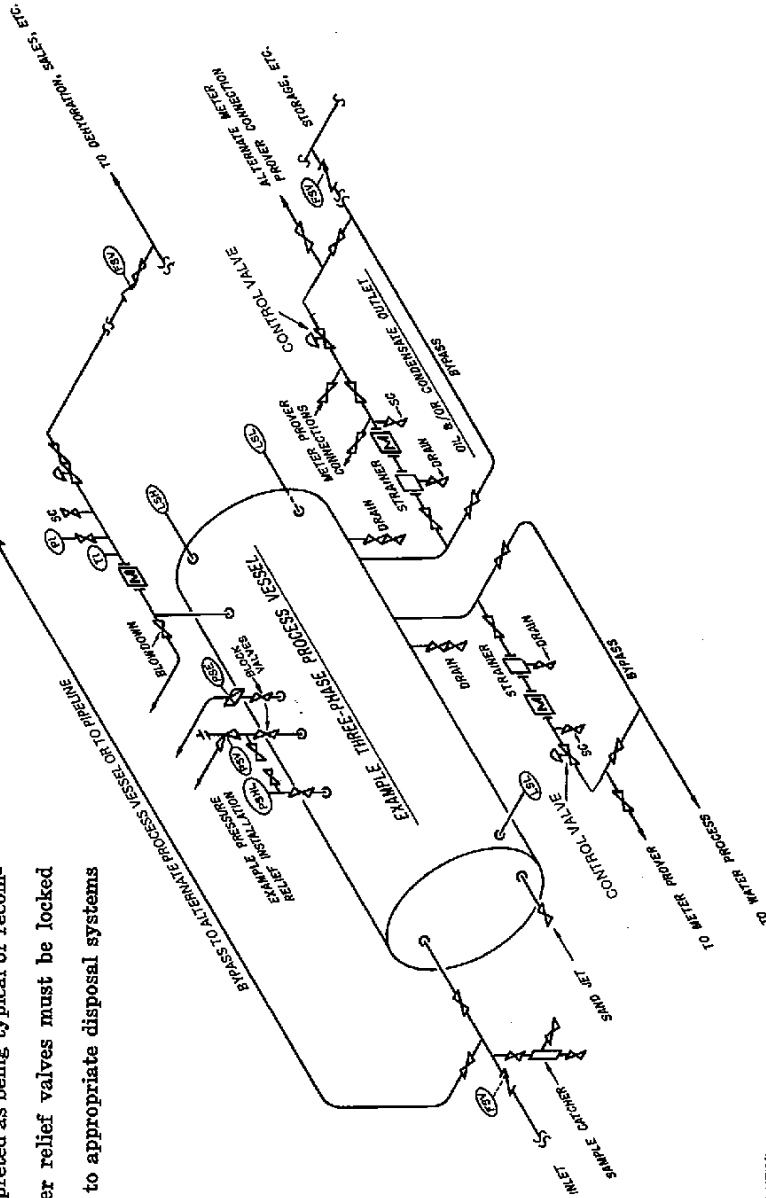

**FIGURE 5.2**  
**EXAMPLE SCHEMATIC DRAWING OF**  
**THREE-PHASE PROCESS VESSEL**  
**SHOWING VARIOUS ACCESSORIES**

**LEGEND**

DEVICE	I. S. A. DESIGNATION
#	FLUID OR GAS METER
PI	PRESSURE INDICATOR
TI	TEMPERATURE INDICATOR
SC	SAMPLE CONNECTION
PSV	PRESSURE SAFETY VALVE
PSE	PRESSURE SAFETY ELEMENT
FSV	FLOW SAFETY VALVE
POCV	PILOT OPERATED CONTROL VALVE
LSH	LEVEL SAFETY HIGH
PSHL	PRESSURE SAFETY HIGH-LOW
LSL	LEVEL SAFETY LOW



exchanger. A separate scrubber may be required.

- c. Heating systems (except hot water or steam) should preferably be pneumatically tested in accordance with Section 8.4.c. If hydrostatically tested, provisions should be made for removal of all water from the system before placing in service. Additionally, any water remaining after draining should be removed at startup, by slowly bringing the system to 212°F and venting the generated steam. Care should be taken to ensure that each branch of the system has circulation during this period.
- d. The exhaust stream from a glycol reboiler contains steam and hydrocarbon vapors. Caution should be exercised in the design of reboiler exhaust piping to prevent back pressure, ignition, and condensation problems.

### 5.8 Pressure Relief and Disposal Systems.

- a. **General.** Pressure relief and disposal systems are required to prevent over pressure of process components and to dispose of the relieved product in a safe manner. Some possible causes of over pressure are downstream blockage, upstream control valve malfunction, and external fire.

- (1) The commonly used safety relief devices are the conventional spring loaded relief valve, the balanced bellows spring loaded relief valve, the pilot operated relief valve, the pressure-vacuum relief valve, and the rupture disc. For a complete description, operation, sizing, pressure setting, and application guide, see ASME Section VIII, API RP 520 Part I, API RP 521 and API RP 14C.
- (2) Relief devices in gas or vapor service should normally be connected to either the vessel vapor space or the outlet piping. They should be located upstream of wire mesh mist extractors. Liquid relief devices should be located below the normal liquid level.
- (3) If vessels with the same operating pressure are in series, a relief device set at the lowest design pressure in the system may be installed on the first vessel. If any remaining vessel can be isolated, a relief device sized for fire or thermal expansion is required. Relief devices should be located so they cannot be isolated from any part of the system being protected.

- b. **Relief Device Piping.\***

- (1) If a spring loaded relief valve is used, it may have a full opening block or check valve upstream plus an external test port for testing and calibrating. If not, it will be necessary to remove the valve for testing. If a pilot operated relief valve is used, the upstream valving is not required for testing purposes.
- (2) Should the relief device have to be removed, process systems connected to a common

relief header must be shut down. Alternatively, a full opening block or check valve may be installed downstream of relief devices if connecting to a common relief header. All block valves installed either upstream or downstream of relief devices should be equipped with locking devices and operated in accordance with ASME Section VIII, Appendix M.

- (3) Piping on the exhaust side of relief devices should be designed to minimize stress on the device. The piping should also be designed to withstand the maximum back pressure to which it could be subjected. The allowable working pressure of relief valves is covered by API Spec 526.

- c. **Relief (Disposal) System Piping.** The relief system and piping should be designed to dispose of the relieved product in a safe and reliable manner. The system and piping should be designed to prevent liquid accumulation so that the design relieving capacity of any of the pressure relieving devices is not reduced. Additionally, the design should limit back pressure. The maximum possible back pressure at each relief point should be determined. This is particularly important where two or more relief devices may relieve simultaneously into the same disposal system. The materials, fittings, welding and other design criteria should conform to the respective parts of this RP and to API RP 520, Part II.

- (1) Vent or flare structures should be designed to prevent buckling caused by wind moment. Vent or flare structures should preferably be installed on the down wind side of the platform, taking into account helicopter and boat approaches, etc. In determining height and distance from the platform, consideration should be given to accidental ignition due to lightning, falling burning fluid, and heat radiation.
- (2) When hydrocarbon vapors are discharged into the atmosphere, mixtures within the flammable range will occur downstream of the outlet. To determine the location of this flammable mixture, and the intensity of the heat should the mixture become ignited, refer to API RP 521 and API Proceedings, Vol 43 (III) (1963), Pages 418-433. When toxic vapors are discharged into the atmosphere, systems should be designed in accordance with EPA AP-26, *Workbook of Atmospheric Dispersion Estimates*.
- (3) If feasible, all relief systems should be designed for a minimum pressure of 50 psig in order to contain flashback. In most cases, vents from atmospheric pressure equipment should be equipped with flame arrestors for flashback protection. Flame arrestors are subject to plugging with ice and should not be used in cold climates. Flame arrestors should be inspected periodically for paraffin build-up.

**5.9 Drain Systems.** Drain systems should be designed to collect and dispose of contaminants from all sources. A good drain system prevents contaminants from spilling overboard; prevents the accumulation of flammable liquids on the deck or pans; and promotes good housekeeping practices.

\*This section applies to systems covered by ASME Section VIII, Division 1. Refer to ASME Boiler and Pressure Vessel Code Section IV for heating boilers.

- a. **Pressure Drains.** When pressure (closed) drains from pressure vessels are used, they should be piped directly to the disposal facilities, independent of the gravity drains, to prevent the introduction of fluids from the pressure drains into the gravity drains. The design pressure of the interconnecting piping and drain valve on each process component should equal or exceed the highest pressure to which the system could be subjected and correspond to the highest working pressure process component in the system. Piping should be in accordance with Sections 2, 3, and 4. A separate closed drain system should be provided for hydrogen sulfide service to permit safe disposal of the fluids.
- b. **Gravity Drains.** Platform decks and skid pans are usually drained by gravity to the disposal facilities. A wide variety of materials may be satisfactory for this service. If steel pipe not satisfactory for hydrocarbon service is used, it should be marked in accordance with Section 2.1.d. Consideration should be given to minimize bends and flow restrictions in the system. The gravity drain system should be equipped with one or more vapor traps or other means to prevent gas migration from the collection vessel to the open drains. Piping should be installed with a downward slope on the order of  $\frac{1}{4}$  inch per foot. In some cases, it may be necessary to install runs in a horizontal plane, but in no circumstances should upslopes be permitted. Clean-out connections should be provided.

**5.10 Bridge Piping Between Platforms.** Design of bridge piping is similar to other piping design except

that platform movement must also be considered. Once the maximum platform movement has been determined, design should be in accordance with Section 2.8.

**5.11 Risers.** Risers should be designed for maximum wave loading, internal pressure, marine traffic, and other environmental conditions. If bottom scouring action is anticipated, the lower end of risers should be jetted below the mudline, when feasible, to avoid undue stresses. Risers on the exterior of that side of the jacket normally accessed by boats, should be protected by bumpers. See Section 6.5.a. (3) for corrosion protection in the splash zone.

**5.12 Sampling Valves.** Valves for sampling process streams should be provided at appropriate locations. Valves should be located so that representative samples will be obtained. Sample valves may be used in conjunction with sample catchers or with sample tubes which extend into the center of the pipe. Consideration should be given to the quality and condition of the stream at each location. Valve design and piping should allow cleaning or rodding of valves which may become plugged with solids. Valves subject to large pressure drops may be quickly cut out. Double valving and proper sampling procedures can minimize such problems. Sample valves are usually  $\frac{1}{2}$  inch austenitic stainless steels (See Section 3.5.a).

#### 5.13 References.

Loudon, D. E., "Requirements for Safe Discharge of Hydrocarbons to Atmosphere", *API Proceedings*, Vol. 43 (III) (1963), Pages 418-433.

## SECTION 6

### CONSIDERATIONS OF RELATED ITEMS

**6.1 General.** This section contains miscellaneous considerations related to piping systems.

**6.2 Layout.** The following items should be considered when planning piping layout on production platforms:

- a. Safety of personnel.
- b. Compatibility with vessel, equipment, and skid arrangement (See API RP 2G).
- c. Accessibility to equipment.
- d. Use of natural supports.
- e. Necessity of suitable walkways.

**6.3 Elevations.** Piping elevation on platforms should be determined by such things as fluid handled, temperature, purpose and personnel access. Piping should not be installed on grating or flooring; it should have adequate clearance for maintenance. Overhead piping should be arranged to provide sufficient personnel head clearance.

**6.4 Piping Supports.** Platform piping should be supported on racks, stanchions or individual standoffs. The location and design of supports are dependent upon routing, media, weight, diameter, shockloads, vibration, etc. Consideration should also be given to seal welding to minimize corrosion; providing sufficient clearance to permit painting; and installing doublers (additional metal) under clamps and saddles. Valve supports should not interfere with removal of the valve for repair or replacement. See Sections 2.8 and 5.3.e of this RP and ANSI B31.3 for a discussion of piping flexibility and support requirements.

#### 6.5 Other Corrosion Considerations.

**a. Protective Coatings for External Surfaces.** Design, selection and inspection of an external piping system should be based on NACE Standard RP-01-76, Sections 10, 12, 13 and 14. Additional points to consider with external coatings are provided below.

- (1) **Types of Platform Piping Coating Systems.** All steel piping should be protected with a coating (painting) system which has been proven acceptable in a marine environment by prior performance or by suitable tests.
- (2) **Selection of Platform Piping Coating Systems.** When selecting coating systems, the following points should be considered:
  - (a) Surface preparation.
  - (b) Temperature ranges (maximum-minimum) expected.
  - (c) Dry and/or wet surfaces.
  - (d) Chemical contamination expected.
  - (e) Location of equipment under consideration (height above splash zone, maximum wave height, etc.).
  - (f) Abrasion expected.
  - (g) Application of coating system.
  - (h) Maintenance.

After the above requirements have been determined, they should be submitted to the operator's Corrosion Engineer, a reputable paint manufacturer's representative, or a consulting engineering firm for specific recommendations, specifications, and inspection services.

Tapes and extruded coatings should generally not be used on platform piping. Experience has shown that severe corrosion can occur beneath these protective materials without any visible evidence. Because of the difficulty in sandblasting on platforms, it is desirable to sandblast, prime, and/or paint pipe and accessories onshore.

- (3) **Risers.** Risers should be protected in the splash zone.
- b. **Corrosion Protection for Internal Surfaces.** The best method to alleviate internal metal loss depends on the type and severity of the corrosion. Each case should be considered individually. NACE Standard RP-01-76 provides guidelines on detecting and controlling piping internal corrosion.
  - (1) **Process Piping.** Protective type coatings are not generally recommended for process piping internals. Potential solutions include:
    - (a) Dehydration of process streams.
    - (b) Use of corrosion inhibitors.
    - (c) Sizing of pipe for optimum velocity.
    - (d) Use of corrosion resistant metals.
  - (2) **Water Piping.** Potential solutions to minimize internal corrosion of water service piping include:
    - (a) Oxygen removal and/or exclusion.
    - (b) Chemical treatment (corrosion inhibition, biocides, scale and pH control).
    - (c) Protective coating and linings (plastics and cement).
    - (d) Non-metallic piping.
    - (e) Control of solids (sand, mud, sludge).
  - (3) **Protective Coatings.** If internal coatings are used, the piping should be designed to facilitate fabrication without damage to the coatings.
- c. **Compatibility of Materials.** When different metals are coupled together in the presence of an electrolyte, galvanic action will occur. The greater the difference in electromotive force (emf) of the metals in the galvanic series, the more severe the corrosion. The possibility of galvanic corrosion should be taken into account when selecting the materials of construction for piping, valves and fittings. Some general guidelines follow:
  - (1) Whenever possible, use the same metal throughout, or metals close together on the galvanic series. The carbon steel materials recommended in Sections 2, 3, and 4 are compatible.
  - (2) The following alternatives should be considered if it is necessary to utilize differing metals:
    - (a) break the couple with unions, nipples, bushings or sleeves made of a non-conducting material.
    - (b) exclude the electrolyte by the application of a protective coating to one or both metals.
    - (c) keep the less noble or anodic member large in comparison with the more noble metal.

d. **Non-Destructive Erosion and/or Corrosion Surveys.** Access should be provided to points in the piping system where erosion and/or corrosion is anticipated. These points should be examined, as soon as practical after start-up, by radiographic or ultrasonic methods and documented for comparison with future surveys. Special emphasis should be given to well flowlines, bends and production manifolds.

e. **Cathodic Protection.** If the submerged portion of a pipeline is to be cathodically protected by a system other than that used to protect the platform, its riser should be isolated from the platform. This may be accomplished with an insulating flange above the water and insulating material inserts within the stand-off clamps below the insulating flange.

**6.6 Thermal Insulation.** Thermal insulation should be used on platform piping for personnel protection, prevention of combustion from hot surfaces, heat conservation, freeze protection and prevention of moisture or ice on piping. For personnel protection, all readily accessible surfaces operating above 160°F should be insulated. Surfaces with a temperature in excess of 400°F should be protected from liquid hydrocarbon spillage, and surfaces in excess of 900°F should be protected from combustible gases.

a. Guidelines for proper insulation include:

- (1) Piping should be properly cleaned and primed prior to insulating.
- (2) Insulating material should be selected for the particular temperature conditions. Insulating material, such as magnesia, that could deteriorate or cause corrosion of the insulated surface if wet, should not be used. Some commonly used insulating materials are calcium silicate, mineral slagwool, glass fiber and cellular glass.
- (3) A vapor barrier should be applied to the outer surface of the insulation on cold piping.
- (4) Insulation should be protected by sheet metal jacketing from weather, oil spillage, mechanical wear, or other damage. If aluminum sheet metal is used for this purpose, it should be protected by an internal moisture barrier.
- (5) To prevent H<sub>2</sub>S from concentrating around the bolts, flanges should not be insulated in H<sub>2</sub>S service.
- (6) Certain heating fluids are not compatible with some insulating materials and auto-ignition may occur. Caution should be exercised in selecting materials.
- (7) Certain insulation materials may be flammable.
- (8) Preformed insulation and jacketing are available for various size pipe and fittings.

b. Tables 6.1 to 6.3 provide typical minimum insulation thicknesses for various conditions of temperature and service.

**6.7 Noise.** In the design of platform piping systems, provisions should be made to protect personnel from harmful noise. Problems and solutions are discussed in depth in API Medical Research Report EA 7801, *Guidelines on Noise*. A general discussion of noise related to piping systems is included in this section.

a. Noise in a piping configuration is caused by the turbulence of a fluid passing through the system. Turbulence is created downstream of restricted openings and increases as the fluid velocity increases. Most noises in piping systems may be attributed to the various types of control valves. The sound pressure level may be calculated for control valves from formulas and data supplied by the various manufacturers.

b. The fundamental approach to noise control in piping systems should be to avoid or minimize the generation of harmful noise levels. Methods that may be effective in avoiding such levels in piping systems include:

- (1) Minimize fluid velocities. The noise levels generated by the recommended velocities in Section 2 should be acceptable.
- (2) Select control valves of a type or with special trim to minimize noise.

c. Methods that may be effective in minimizing noises in piping systems include:

- (1) Avoid abrupt changes in flow direction.
- (2) Use venturi (conical) type reducers to avoid abrupt changes in flow pattern.
- (3) Use flow straightening vanes to reduce large scale turbulence.
- (4) Use extra heavy wall pipe and fittings to attenuate sound and vibration (See API Medical Research Report EA 7301).
- (5) Use acoustic insulation and/or shielding around pipe and fittings to absorb or isolate sound.
- (6) Use flow stream silencers for extreme cases.

**6.8 Pipe, Valves and Fittings Tables.** Detailed information concerning pipe, valves and fittings may be readily shown using tables. Information that may be shown in the tables includes size ranges, general specifications, valve figure numbers, pressure ratings, temperature limitations, pipe schedules, material specifications, special notes, etc. Such tables are generally prepared by an operator for use as a general company-wide guide. Examples of Pipe, Valves and Fittings Tables are provided in Appendix C.

**6.9 Inspection, Maintenance, Repairs and Alterations** are important considerations after a platform piping system has been commissioned. API 510, which is written for Pressure Vessels, contains guidelines on these topics which can also be applied to piping systems.

**TABLE 6.1**  
**TYPICAL HOT INSULATION THICKNESS (INCHES)**

Maximum Temperature (°F)	Nominal Pipe Size, Inches								
	1	2	3	4	5	6	7	8	9
	1½ & Smaller	2	3	4	6	8	10	12 & Larger	
250	1	1	1	1½	1½	1½	1½	1½	1½
500	1	1½	1½	1½	2	2	2	2	2
600	1½	1½	2	2	2	2½	2½	2½	2½
750	2	2	2	2	2½	3	3	3	3

**TABLE 6.2**  
**TYPICAL COLD INSULATION THICKNESS (INCHES)**

Minimum Temperature (°F)	Nominal Pipe Size, Inches																			Flat Surf.	
	1	2	3	4	5	6	7	8	9	10	11	12	13	14	15	16	17	18	19		20
	½	¾	1	1½	2	2½	3	4	6	8	10	12	14	16	18	20	24	30			
40	1	1	1	1	1	1	1	1	1	1½	1½	1½	1½	1½	1½	1½	1½	1½	1½	1½	1½
30	1	1	1	1½	1½	1½	1½	1½	1½	1½	1½	1½	1½	1½	1½	1½	1½	1½	1½	1½	1½
20	1½	1½	1½	1½	1½	1½	1½	1½	2	2	2	2	2	2	2	2	2	2	2	2	2
10	1½	1½	1½	1½	2	2	2	2	2	2	2½	2½	2½	2½	2½	2½	2½	2½	2½	2½	2½
0	1½	2	2	2	2	2	2	2½	2½	2½	2½	2½	2½	2½	2½	2½	2½	3	3	3	3
-10	2	2	2	2	2	2½	2½	2½	2½	3	3	3	3	3	3	3	3	3	3	3	3½
-20	2	2	2	2½	2½	2½	2½	2½	3	3	3	3	3	3½	3½	3½	3½	3½	3½	3½	4

**TABLE 6.3**  
**TYPICAL INSULATION FOR PERSONNEL PROTECTION**  
**(Applicable Hot Surface Temperature Range (°F))**

Nominal Pipe Size (Inches)	Nominal Insulation Thickness (Inches)						
	1	1½	2	2½	3	3½	4
	½	160-730	731-1040	1041-1200	----	----	----
¾	160-640	641-940	941-1200	----	----	----	----
1	160-710	711-960	961-1200	----	----	----	----
1½	160-660	661-880	881-1200	----	----	----	----
2	160-640	641-870	871-1090	1091-1200	----	----	----
2½	160-620	621-960	961-1160	1161-1200	----	----	----
3	160-600	601-810	811-1000	1001-1200	----	----	----
4	160-600	601-790	791-970	971-1125	1126-1200	----	----
6	160-550	551-740	741-930	931-1090	1091-1200	----	----
8	----	160-740	741-900	901-1090	1091-1200	----	----
10	----	160-750	751-900	901-1060	1061-1200	----	----
12	----	160-740	741-900	901-1030	1031-1170	1171-1200	----
14	----	160-700	701-850	851-1000	1001-1130	1131-1200	----
16	----	160-690	691-840	841-980	981-1120	1121-1200	----
18	----	160-690	691-830	831-970	971-1100	1101-1200	----
20	----	160-690	691-830	831-970	971-1100	1101-1200	----
24	----	160-680	681-820	821-960	961-1090	1091-1200	----
30	----	160-680	681-810	811-950	951-1080	1081-1200	----
Flat Surface*	160-520	521-660	661-790	791-900	901-1010	1011-1120	1121-1200

\*Application range also applies to piping and equipment over 30 inches in diameter.

## SECTION 7

### INSTALLATION AND QUALITY CONTROL

**7.1 General.** This section covers fabrication, assembly, erection, inspection, testing and related operations associated with the installation and quality control of metallic and non-metallic platform piping systems. Fabrication, assembly, erection, inspection, testing and related operations should comply with ANSI B31.3, except as modified herein.

**7.2 Authorized Inspector.** A minimum of 5 years experience in design, fabrication or inspection of industrial pressure piping should be required to qualify as an authorized inspector.

#### 7.3 Welding.

**a. Safety Precautions.** Prior to and during burning and welding in any area on a platform which contains hydrocarbon process equipment, thorough checks should be made visually, and with a portable combustible gas detector, to determine that the area is free of flammable liquids and combustible gas mixtures. The supervisor on the platform should have knowledge of all simultaneous activities.

(1) An inspection should be made prior to the commencement of any burning or welding to ensure the welding machines are equipped with spark arrestors and drip pans; welding leads are completely insulated and in good condition; oxygen and acetylene bottles are secured properly; and the hoses are leak free and equipped with proper fittings, gages, and regulators.

(2) During welding or burning operations in an area which contains hydrocarbon process equipment, one or more persons, as necessary, should be designated for fire watch. Persons assigned to fire watch should have no other duties while actual burning or welding operations are in progress. They should have operable fire fighting equipment in their possession and be instructed in its use. No welding or burning (except hot taps) should be permitted on lines or vessels until they have been isolated and rendered free of combustible hydrocarbons.

(3) Adequate lighting should be provided on a platform when welding or burning at night.

**b. Welding Procedure Qualification.** Tests should be conducted to qualify welding procedures to be utilized. Procedure qualification methods and requirements are detailed in ANSI B31.3.

**c. Welder Qualification.** Welders should be qualified using the specific qualified welding procedure for the proposed job. ANSI B31.3 contains details for qualifying welders, including the variables that make requalification necessary.

**d. Welding Records.** Test records of the welding procedure qualification and the welder performance qualification should be maintained per ANSI B31.3.

**e. Welding Requirements.** ANSI B31.3 covers welding requirements and in addition welding should not be done if there is danger that the quality of the weld may be affected by atmospheric conditions.

**f. Heat Treatment.** ANSI B31.3 covers heat treatment, including pre-heat and stress relieving.

**g. Examination and Inspection.** Visual, radiographic and ultrasonic examination and inspection should comply with ANSI B31.3. Additional recommendations are provided below.

(1) **Radiographic Inspection.** It is recommended that platform piping in hydrocarbon service regardless of service temperature and pressure be radiographically examined in accordance with Table 7.1.

**TABLE 7.1**  
**MINIMUM EXTENT OF RADIOGRAPHIC**  
**WELD EXAMINATION**  
**FOR CARBON STEEL MATERIAL**

Pressure Class	Percent of Welds
150 lb to 600 lb ANSI.....	10%
900 lb and 1500 lb ANSI.....	20%
2500 lb ANSI, 5000 lb API, and Higher.....	100%

**7.4 Pressure Testing.** Prior to being placed in operation, piping should be pressure tested for leaks. Preparation for testing, hydrostatic and pneumatic testing are covered by ANSI B31.3 except as modified below.

**a. Hydrostatic Tests.** Water should be used in all hydrostatic testing unless it would have an adverse effect on the piping or operating fluid. Any flammable liquids used for testing should have a flash point above 150°F.

(1) When a system is to be tested, the following equipment should be isolated:

- (a) Pumps, turbines and compressors.
- (b) Rupture discs and relief valves.
- (c) Rotometers and displacement meters.

(2) The following equipment should be tested to design pressure and then isolated:

- (a) Indicating pressure gages, when the test pressure will exceed the scale range.
- (b) External float type level shutdown devices and controllers, when the float is not rated for the test pressure. The float should be subjected to design pressure; then the float chamber should be isolated from the system.

(3) Check valves should be held open and block and bleed ball valves should be in the one half open position during testing.

**b. Pneumatic Tests.** Pneumatic tests should be performed in accordance with ANSI B31.3 when hydrostatic tests would be undesirable, such as in instrument air, heating fluid, and refrigeration systems. Inasmuch as pneumatic testing may create an unsafe condition, special precautions should be taken, and careful supervision should be provided during testing. Only air or nitrogen (with or without tracers) should be used as the test medium. Each test system should be kept as small as practical.

- (1) The test pressure should be 1.1 times the maximum design pressure, or 100 psig, whichever is the lesser. To guard against brittle fracture hazards, the minimum metal temperature for all components during the test should be 60°F.
- (2) Pressure should be gradually increased to not more than 25 psig, and held until all joints have been inspected for leaks with soap solution. If no leaks are found, the pressure should be increased in increments

of approximately 15 psi until the final test pressure is reached. The pressure should then be reduced to 90% of test pressure, and held for a sufficient length of time to permit inspection of all joints, welds, and connections with soap solution.

**7.5 Test Record.** Test records including welding procedure qualifications, welder performance qualifications and pressure testing should be in accordance with ANSI B31.3.

**APPENDIX A**  
**EXAMPLE PROBLEMS**

**Introduction.** This appendix demonstrates, by means of solutions to example problems, applications of the piping design guidelines presented in this RP.

**EXAMPLE A1**  
**FLOWLINE PIPING DESIGN**

**A1.1 Problem Statement.** Design a flowline for a gas-condensate completion.

**A1.1.1** The completion is expected to have the following initial characteristics:

- a. Shut-in wellhead pressure = 5500 psig.
- b. Maximum test and production flow rate expected (including surge):  
 $Q_g = 15$  million cubic feet/day  
 $[S_g = .65 \text{ (air = 1)}]$ .  
 $Q_l = 50$  barrels condensate/million cubic feet gas [ $S_l = .80 \text{ (water = 1)}$ ].
- c. Flowing tubing pressure = 4500 psig.
- d. Flowing temperature = 120°F.

**A1.1.2** The completion is expected to have the following characteristics at depletion:

- a. Flowing tubing pressure = 1500 psig.  
 $Q_g = 10$  million cubic feet/day  
 $[S_g = .65 \text{ (air = 1)}]$ .  
 $Q_l = 20$  barrels condensate/million cubic feet gas [ $S_l = .80 \text{ (water = 1)}$ ], and 1500 barrels of produced water per day [ $S_l = 1.08 \text{ (water = 1)}$ ].

**A1.1.3** Equivalent length of flowline = 50 feet.

**A1.1.4** Flowline to be designed for wellhead pressure.

**A1.2 Solution.**

**A1.2.1 General.** The following items should be considered:

- a. Erosional velocity.
- b. Pressure containment.
- c. Noise.
- d. Pressure drop.

**A1.2.2 Erosional Velocity.** Since the well will flow continuously and little or no sand production is anticipated, Equation 2.8 with an empirical constant of 100 will be used to calculate the maximum allowable erosional velocity (See Section 2.5.a).

$$V_e = \frac{c}{\sqrt{\rho_m}} \quad \text{Eq. 2.8}$$

where:

- $V_e$  = fluid erosional velocity, feet/second.
- $c$  = empirical constant;  
= 100 for continuous service with minimum solids.
- $\rho_m$  = gas/liquid density at operating pressure and temperature, lbs/ft<sup>3</sup>.

**A1.2.2.1**  $\rho_m$  will be calculated for initial and final flowing conditions, to determine which conditions control, using Equation 2.9.

$$\rho_m = \frac{12409 S_l P + 2.7 R S_g P}{198.7P + RTZ} \quad \text{Eq. 2.9}$$

where:

- $P$  = operating pressure, psia.
- $S_l$  = liquid specific gravity (water = 1; use average gravity for hydrocarbon-water mixtures) at standard conditions.
- $R$  = gas/liquid ratio, cu ft/barrel at standard conditions.
- $T$  = operating temperature, °R.
- $S_g$  = gas specific gravity (air = 1) at standard conditions.
- $Z$  = gas compressibility factor, dimensionless.

**For Initial Conditions:**

$$\begin{aligned} S_l &= .80 \\ P &= 4500 \text{ psig} + 14.7 = 4515 \text{ psia} \\ R &= \frac{1,000,000 \text{ cu ft}}{50 \text{ barrels}} = 20,000 \text{ cu ft/barrel} \\ S_g &= .65 \\ T &= 120^\circ\text{F} + 460 = 580^\circ\text{R} \\ Z &= 0.91 \end{aligned}$$

**Inserting in Equation 2.9:**

$$\begin{aligned} \rho_m &= \frac{12409 \times .80 \times 4515 + 2.7 \times 20,000 \times .65 \times 4515}{198.7 \times 4515 + 20,000 \times 580 \times 0.91} \\ &= 17.8 \text{ lbs/ft}^3 \text{ (initial)} \end{aligned}$$

**For Final Conditions:**

$$\begin{aligned} S_l &= \frac{10 \text{ mmcf/d} \times 20 \text{ bbl/mmcf} \times .80 + 1500 \text{ bbl/day} \times 1.08}{10 \text{ mmcf/d} \times 20 \text{ bbl/mmcf} + 1500 \text{ bbl/day}} \\ &= 1.04 \\ P &= 1500 \text{ psig} + 14.7 = 1515 \text{ psia} \\ R &= \frac{10 \text{ mmcf/d}}{5880 \text{ cu ft/barrel}} \\ &= \frac{10 \text{ mmcf/d} \times 20 \text{ bbl/mmcf} + 1500 \text{ bbl/day}}{5880 \text{ cu ft/barrel}} \\ S_g &= .65 \\ T &= 120^\circ\text{F} + 460 = 580^\circ\text{R} \\ Z &= 0.81 \end{aligned}$$

**Inserting in Equation 2.9:**

$$\begin{aligned} \rho_m &= \frac{12409 \times 1.04 \times 1515 + 2.7 \times 5880 \times .65 \times 1515}{198.7 \times 1515 + 5880 \times 580 \times 0.81} \\ &= 11.5 \text{ lbs/ft}^3 \text{ (final)} \end{aligned}$$

**A1.2.2.2** Using the above values in Equation 2.8 gives:

$$\begin{aligned} V_e \text{ (initial)} &= \frac{100}{\sqrt{17.8}} = 23.7 \text{ ft/sec} \\ V_e \text{ (final)} &= \frac{100}{\sqrt{11.5}} = 29.5 \text{ ft/sec} \end{aligned}$$

**A1.2.2.3** Using Equation 2.10, the minimum allowable cross-sectional areas can be determined

$$A = \frac{9.35 + \frac{RTZ}{21.25P}}{V_e} \quad \text{Eq. 2.10}$$



where:

A = minimum pipe cross-sectional area required, in<sup>2</sup>/1000 barrels liquid per day

For Initial Conditions:

$$A = \frac{9.35 + \frac{20,000 \times 580 \times 0.91}{21.25 \times 4515}}{23.7}$$

= 5.04 in<sup>2</sup>/1000 bbl/day

A = 5.04 in<sup>2</sup>/1000 bbl/day × (15 mmcf/d × 50 bbl/mmcf)  
= 3.78 in<sup>2</sup> (initial)

For Final Conditions:

$$A = \frac{9.35 + \frac{5880 \times 580 \times 0.81}{21.25 \times 1515}}{29.5} = 3.23 \text{ in}^2/1000 \text{ bbl/day}$$

A = 3.23 in<sup>2</sup>/1000 bbls/day × (1500 bbl/day + 10 mmcf/d × 20 bbl/mmcf/d)  
= 5.49 in<sup>2</sup> (final)

A1.2.2.4 Although the allowable erosional velocity is higher for the final conditions, the line size will still be controlled by the final conditions since the liquid volume is higher.

A1.2.2.5 A will be converted into an inside pipe diameter as follows:

$$A = \frac{\pi d_i^2}{4}$$

d<sub>i</sub> (initial) =  $\sqrt{\frac{4 \times 3.78 \text{ in}^2}{\pi}}$  = 2.19 inches inside diameter.

d<sub>i</sub> (final) =  $\sqrt{\frac{4 \times 5.49 \text{ in}^2}{\pi}}$  = 2.64 inches inside diameter.

A1.2.3 Pressure Containment. A preliminary line size can now be selected using Table 2.5. The required pressure rating of the line must be greater than 5500 psig.

A1.2.3.1 The two obvious choices are listed below:

Nominal Line Size	Schedule	Inside Diameter	Grade B Pipe Max Working Pressure
3 inch	XXS	2.30 inch	6090 psig
4 inch	XXS	3.15 inch	5307 psig

The 3 inch nominal pipe has the required pressure rating, but the internal diameter is too small for the final conditions. The 4 inch nominal pipe has sufficient internal diameter for the final conditions, but the required working pressure is slightly deficient if Grade B pipe is used.

A1.2.3.2 The final selection requires engineering judgment. The following alternatives should be evaluated:

- Recheck the source of the shut-in wellhead pressure requirements. Often, nominal values somewhat higher than actual requirements are supplied to piping designers. If the actual shut-in pressure was less than 5307 psig, the 4 inch nominal XXS would be the proper choice.
- Check the mill certification for available 4 inch nominal XXS pipe, to determine the actual yield strength. Although the specified minimum yield strength for Grade B pipe is 35,000 psi, most pipe exceeds the minimum yield by 10% or so. In this case, if the actual yield strength were 36,272 psi, the 4 inch nominal XXS pipe would be the proper choice.

$$\frac{\text{Actual yield strength}}{35,000 \text{ psi}} = \frac{5500 \text{ psig}}{5307 \text{ psig}}$$

Actual yield strength = 36,272 psi

- Check availability of 4 inch nominal XXS Grade X42 pipe which will meet the required 5500 psig pressure requirement.
- Consider using a pressure relief device on a 4 inch nominal XXS line until the wellhead shut-in pressure declines to 5307 psig.
- Recheck the final well conditions prediction to determine if slightly lower flows might exist which would allow a 3 inch nominal XXS line to suffice for the life of the well. The amount of surge included in the maximum flow rate should be examined in detail to see if it is reasonable.
- Consider installing a 3 inch nominal XXS line initially, then replacing it with a larger (inside diameter) line later in the life.

A1.2.4 Noise. The velocity (and relative indication of the noise) in the line will be determined for initial and final conditions to determine which conditions control.

A1.2.4.1 The velocity can be determined as follows:

For Initial Conditions:

weight flow of gas  
=  $\frac{15 \text{ mmcf/d} \times .65 \times 29 \text{ lbs/lb mol air}}{86,400 \text{ sec/day} \times 379 \text{ cu ft/lb mol}}$   
= 3.64 lbs/sec

weight flow of condensate  
=  $\frac{15 \text{ mmcf/d} \times 50 \text{ bbls/mmcf} \times .80 \times 350 \text{ lbs/bbl water}}{86,400 \text{ sec/day}}$   
= 2.43 lbs/sec

Total weight flow of wellstream (initial) = 11.07 lbs/sec

For Final Conditions:

weight flow of gas  
=  $\frac{10 \text{ mmcf/d} \times .65 \times 29 \text{ lbs/lb mol air}}{86,400 \text{ sec/day} \times 379 \text{ cu ft/lb mol}}$   
= 5.75 lbs/sec

weight flow of condensate  
=  $\frac{10 \text{ mmcf/day} \times 20 \text{ bbl/mmcf} \times .80 \times 350 \text{ lbs/bbl water}}{86,400 \text{ sec/day}}$   
= .65 lbs/sec

weight flow of water  
=  $\frac{1500 \text{ bbl/day} \times 350 \text{ lbs/bbl}}{86,400 \text{ sec/day}}$   
= 6.08 lbs/sec

Total weight flow of wellstream (final) = 12.48 lbs/sec

A1.2.4.1.1 The flowing velocity will be determined above for erosional velocity, the total volume flows would be:

final flow volume =  $\frac{12.48 \text{ lbs/sec}}{11.5 \text{ lbs/ft}^3}$  = 1.1 ft<sup>3</sup>/sec

initial flow volume =  $\frac{11.07 \text{ lbs/sec}}{17.8 \text{ lbs/ft}^3}$  = .62 ft<sup>3</sup>/sec

Thus the final conditions control the maximum velocity.

A1.2.4.1.2 The flowing velocity will be determined for 3 and 4 inch nominal XXS line sizes.

Velocity (3") =  $\frac{1.1 \text{ ft}^3/\text{sec}}{\pi/4 \times (2.3/12)^2}$  = 38.2 ft/sec

Velocity (4") =  $\frac{1.1 \text{ ft}^3/\text{sec}}{\pi/4 \times (3.15/12)^2}$  = 20.4 ft/sec

A1.2.4.2 Since the velocity is less than 60 ft/sec (See Section 2.4) in both cases, noise should not be a problem and would not influence the line size selection.

A1.2.5 Pressure Drop in the line may be determined using Equation 2.11.

$$\Delta P = \frac{0.000336f W^2}{d_i^5 \rho_m} \quad \text{Eq. 2.11}$$

where:

$\Delta P$  = pressure drop, psi/100 feet.

$d_i$  = pipe inside diameter, inches.

$f$  = Moody friction factor, dimensionless.

$\rho_m$  = gas/liquid density at flowing pressure and temperature, lbs/ft<sup>3</sup> (Calculate as shown in Equation 2.9).

$W$  = total liquid plus vapor rate, lbs/hr.

A1.2.5.1  $W$  may be determined using Equation 2.12.

$$W = 3180 Q_g S_g + 14.6 Q_l S_l \quad \text{Eq. 2.12}$$

where:

$Q_g$  = gas flow rate, million cubic feet/day (14.7 psia and 60°F).

$S_g$  = gas specific gravity (air = 1).

$Q_l$  = liquid flow rate, barrels/day.

$S_l$  = liquid specific gravity (water = 1).

$$\begin{aligned} W \text{ (initial)} &= 3180 \times 15 \times .65 + 14.6 \times 15 \text{ mmcf/d} \\ &\quad \times 50 \text{ bbl/mmcf} \times .80 \\ &= 39,765 \text{ lbs/hr} \end{aligned}$$

$$\begin{aligned} W \text{ (final)} &= 3180 \times 10 \times .65 + 14.6 \times (10 \text{ mmcf/d} \\ &\quad \times 20 \text{ bbl/mmcf} + 1500 \text{ bbl/day}) \times 1.04 \\ &= 46,483 \text{ lbs/hr} \end{aligned}$$

A1.2.5.2 Using the above values in equation 2.11 gives:

$$\begin{aligned} \Delta P \text{ (initial 3")} &= \frac{0.000336 \times 0.019 \times (39765)^2}{(2.3)^5 \times 17.8} \\ &= 8.9 \text{ psi/100 ft} \end{aligned}$$

$$\begin{aligned} \Delta P \text{ (initial 4")} &= \frac{.000336 \times 0.0196 \times (39765)^2}{(3.15)^5 \times 17.8} \\ &= 1.9 \text{ psi/100 ft} \end{aligned}$$

$$\begin{aligned} \Delta P \text{ (final 3")} &= \frac{.000336 \times 0.0200 \times (46483)^2}{(2.3)^5 \times 11.5} \\ &= 19.6 \text{ psi/100 ft} \end{aligned}$$

$$\begin{aligned} \Delta P \text{ (final 4")} &= \frac{.000336 \times (46483)^2 \times 0.0196}{(3.15)^5 \times 11.5} \\ &= 4.0 \text{ psi/100 ft} \end{aligned}$$

Refer to Figure 2.3 for Moody friction factor ( $f$ ).

A1.2.5.3 Since the line is only 50 feet long, the total pressure drop would not be critical in most cases and probably would not influence line size selection.

**EXAMPLE A2**  
**PUMP SUCTION PIPING DESIGN**

**A2.1 Problem Statement.** A single reciprocating pump will be used to transfer crude oil from a production separator to a remote oil treating facility. Select a suction line size for this pump application. Data for the pumping system is listed below:

**A2.1.1 Operating Conditions of Separator:**

- a. Operating pressure = 60 psig.
- b. Inlet oil volume = 5000 barrels/day.
- c. Inlet water volume = zero.
- d. Oil gravity = 40° API ( $S_1 = .825$ ).
- e. Oil viscosity = 1.5 centipoise at pumping temperature.
- f. Level in separator will be controlled constant by bypassing pump discharge back to separator.
- g. Vessel outlet nozzle = 8 inch ANSI 150.

**A2.1.2 Pump Data:**

- a. Volume handled, 150% of oil inlet (to ensure ability to maintain liquid level during surges) = 7500 barrels/day.
- b. Type Pump = Triplex.
- c. Pump RPM = 200.
- d. Suction Connection = 6 inch ANSI 150.
- e. Discharge Connection = 3 inch ANSI 600.
- f. Required NPSH = 4 psia at operating condition.
- g. Discharge Pressure = 500 psig.
- h. Pump datum located 15 feet below the separator fluid level.

**A2.1.3** The suction line is 50 feet long and contains one Tee, four 90° elbows, two full open ball valves, and one 8 inch x 6 inch standard reducer.

**A2.2 Trial Solution.** From Table 2.3, a suction velocity of 2 feet/second is selected to determine a preliminary line size. From Figure 2.1, for 7500 barrels/day flow rate, a 6 inch Sch. 40 line gives a velocity of 2.4 feet/sec; and an 8 inch Sch. 40 line gives a velocity of 1.4 feet/sec. From this, an 8 inch line (7.98 inch inside diameter) is selected for the first trial.

**A2.2.1 Determine line equivalent length using Table 2.2:**

Elbow equivalent length	= 4 × 9 ft = 36 ft
Ball valves equivalent length	= 2 × 6 ft = 12 ft
Tee Run equivalent length	= 1 × 9 ft = 9 ft
Reducer equivalent length	= 1 × 2 ft = 2 ft
Vessel outlet contraction	= 1 × 12 ft = 12 ft
8 inch line length	= 50 ft

**Equivalent Line Length = 121 ft**

**A2.2.2 Next calculate line friction losses using Equation 2.2:**

$$\Delta P = \frac{0.00115 f Q_1^2 S_1}{d_i^5} \quad \text{Eq. 2.2}$$

where:

- $\Delta P$  = pressure drop, psi/100 feet.
- $f$  = Moody friction factor, dimensionless.
- $Q_1$  = liquid flow rate, barrels/day.
- $S_1$  = liquid specific gravity (water = 1).
- $d_i$  = pipe inside diameter, inches.

**A2.2.2.1** The friction factor,  $f$ , may be found from Figure 2.3 using the Reynolds number calculated from Equation 2.3:

$$Re = \frac{\rho_l d_i V_1}{\mu_l} \quad \text{Eq. 2.3}$$

where:

- $Re$  = Reynolds number, dimensionless.
- $\rho_l$  = liquid density at flowing temperature, lb/ft<sup>3</sup>.
- $d_i$  = pipe inside diameter, feet.
- $V_1$  = liquid flow velocity, ft/sec.
- $\mu_l$  = liquid viscosity, lb/ft-sec;  
= centipoise divided by 1488 or;  
= (centistokes times specific gravity) divided by 1488.

**For this problem:**

$$\begin{aligned} \rho_l &= 62.4 \text{ lbs/ft}^3 \text{ water} \times .825 = 51.49 \text{ lb/ft}^3 \\ d_i &= 7.98 \text{ in}/12 = 0.665 \text{ feet} \\ V_1 &= 1.4 \text{ ft/sec (Fig. 2.1)} \\ \mu_l &= 1.5 \text{ cp}/1488 = 0.001 \text{ lb/ft-sec} \\ Re &= \frac{51.49 \times .665 \times 1.4}{.001} = 47,937 \end{aligned}$$

Using  $Re$  and the steel pipe curve,  $f$  may be found from Figure 2.3.

$$f = 0.023$$

**A2.2.2.2** All of the required values for Equation 2.2 are now known:

$$\begin{aligned} Q_1 &= 7500 \text{ barrels/day} \\ S_1 &= 0.825 \\ d_i &= 7.98 \text{ inches} \\ \Delta P/100 \text{ ft} &= \frac{0.00115 \times 0.023 \times 7500^2 \times 0.825}{(7.98)^5} \\ &= 0.038 \text{ psi/100 feet} \\ \Delta p \text{ Total} &= \frac{0.038 \times 121}{100} = 0.046 \text{ psi} \end{aligned}$$

**A2.2.3** Next determine available NPSH from Equation 2.4.

$$NPSH_a = h_p - h_{vpa} + h_{st} - h_f - h_{vh} - h_a \quad \text{Eq. 2.4}$$

where:

- $h_p$  = absolute pressure head due to pressure, atmospheric or otherwise, on surface of liquid going to suction, feet of liquid.
- $h_{vpa}$  = the absolute vapor pressure of the liquid at suction temperature, feet of liquid.
- $h_{st}$  = static head, positive or negative, due to liquid level above or below datum line (centerline of pump), feet of liquid.
- $h_f$  = friction head, or head loss due to flowing friction in the suction piping including entrance and exit losses, feet of liquid.
- $h_{vh}$  = velocity head =  $V_1^2/2g$ , feet of liquid.
- $h_a$  = acceleration head, feet of liquid.
- $V_1$  = velocity of liquid in piping, feet/second.
- $g$  = gravitational constant (usually 32.2ft/sec<sup>2</sup>)

**A2.2.3.1** Since the oil is in equilibrium with the gas in the separator, the vapor pressure of the oil will be 60 psig also. Thus:

$$h_{vpa} = h_p = \frac{(60 + 14.7) \text{ psia}}{.433 \text{ psi/ft} \times .825} = 209 \text{ feet}$$

$h_{at} = 15 \text{ feet (given)}$

$$h_f = \frac{0.046 \text{ psi}}{.433 \text{ psi/ft} \times .825} = 0.09 \text{ feet}$$

$$h_{vh} = \frac{(1.4 \text{ ft/sec})^2}{2 \times 32.2 \text{ ft/sec}^2} = 0.03 \text{ feet}$$

**A2.2.3.2**  $h_a$  may be determined from Equation 2.5.

$$h_a = \frac{L V_1 R_p C}{K g} \quad \text{Eq. 2.5}$$

where:

$h_a$  = acceleration head, feet of liquid.

$L$  = length of suction line, feet (not equivalent length).

$V_1$  = average liquid velocity in suction line, feet/second.

$R_p$  = pump speed, revolutions/minute.

$C$  = empirical constant for the type of pump;  
= .066 for triplex, single or double acting.

$K$  = a factor representing the reciprocal of the fraction of the theoretical acceleration head which must be provided to avoid a noticeable disturbance in the suction piping;

= 2.0 for crude oil.

$g$  = gravitational constant (32.2 ft/sec<sup>2</sup>).

**Substituting Known Values Into Equation 2.5 yields:**

$$h_a = \frac{50 \times 1.4 \times 200 \times .066}{2.0 \times 32.2} = 14.4 \text{ feet}$$

**A2.2.3.3** The available net positive suction head is:

$$\text{NPSH}_a = 209 - 209 + 15 - .09 - .03 - 14.4 = .48 \text{ feet}$$

**A2.2.4** NPSH required =  $\frac{4 \text{ psia}}{.433 \text{ psi/ft} \times .825} = 11.2 \text{ feet}$

**A2.2.5 Conclusion.** The pump would not operate under these conditions.

**A2.3 Alternate Solutions.** Referring to Section 2.3.b(5), the following alternatives may be considered as ways to increase NPSH<sub>a</sub>.

**A2.3.1 Shorten Suction Line.** Although it might be possible to shorten the line length somewhat, the acceleration head needs to be reduced by at least

$$\left[ 1 - \frac{(14.4 - 11.2 - .48)}{14.4} \right] 100\% = 80\%;$$

so this alternative would not be feasible.

**A2.3.2 Use Larger Suction Pipe to Reduce Velocity.** If a 10 inch pipe were used rather than an 8 inch pipe, the velocity would be reduced from 1.4 ft/sec to .90 ft/sec (Figure 2.1). Likewise, a 12 inch pipe would reduce the velocity to .62 ft/sec. Since neither of the pipe sizes would reduce the velocity by 80% (and thereby reduce the acceleration head by 80%), this alternative would not be feasible.

**A2.3.3 Reduce Pump Speed.** A pump speed of 200 RPM is already very low, so this alternative would not be feasible.

**A2.3.4 Consider a Pump With a Larger Number of Plungers.** The reasonable pump alternative would be to use a quintuplex, rather than a triplex, which would reduce the acceleration head by 40%. Since a greater percentage reduction is required, this alternative is not feasible.

**A2.3.5 Use a Pulsation Dampener.** A properly installed pulsation dampener may reduce the length of line used in Equation 2.5 to 15 (or less) nominal pipe diameters (15 × 8 in/12 in/ft = 10 ft.)

**A2.3.5.1** Recalculate the acceleration head.

$$h_a \text{ (dampener)} = \frac{10 \times 1.4 \times 200 \times .066}{2.0 \times 32.2} = 2.9 \text{ feet}$$

**A2.3.5.2** By using a pulsation dampener, the available NPSH would be:

$$\text{NPSH}_a = 209 - 209 + 15 - .09 - .03 - 2.9 = 11.98 \text{ feet.}$$

**A2.3.5.3** Since the conservative approach was used in determining the line length to recalculate the acceleration head, the available NPSH should be adequate if a pulsation dampener is used.

**A2.3.5.4** If a greater margin of available NPSH over required NPSH is desired, then one of the alternatives discussed above could be included in the system design in addition to the pulsation dampener.

## APPENDIX B

### ACCEPTABLE BUTT WELDED JOINT DESIGN FOR UNEQUAL WALL THICKNESSES

#### SECTION B1

#### GENERAL EXPLANATORY NOTES

**B1.1** Figure B1.1 illustrates acceptable preparations for butt welding pipe ends having unequal wall thicknesses and/or materials of unequal specified minimum yield strength.

**B1.2** The wall thickness of the pipes to be joined, beyond the joint design area, should comply with the design requirements of ANSI B31.3.

**B1.3** When the specified minimum yield strengths of the pipes to be joined are unequal, the deposited weld metal should have mechanical properties at least equal to those of the pipe having the higher strength.

**B1.4** The transition between ends of unequal thickness may be accomplished by taper or welding as illustrated in Figure B1.1, or by means of a prefabricated transition piece not less than one half pipe diameter in length.

**B1.5** Sharp notches or grooves at the edge of the weld, where it joins a slanted surface, should be avoided.

**B1.6** For joining pipes of unequal wall thicknesses and equal specified minimum yield strengths, the principles given herein apply except there is no minimum angle limit to the taper.

#### SECTION B2

#### EXPLANATION OF FIGURE B1.1

##### **B2.1 Internal Diameters Unequal.**

- a. If the nominal wall thicknesses of the adjoining pipe ends do not vary more than 3/32 inch, no special treatment is necessary provided full penetration and bond are accomplished in welding (See sketch (a) of Figure B1.1).
- b. Where the nominal internal offset is more than 3/32 inch and there is no access to the inside of the pipe for welding, the transition should be made by a taper cut on the inside end of the thicker pipe (See sketch (b)). The taper angle should not be steeper than 30°, nor less than 14°.
- c. For stress levels above 20 percent or more of the specified minimum yield strength, where the nominal internal offset is more than 3/32 inch but does not exceed ½ the wall thickness of the thinner pipe, and there is access to the inside of the pipe for welding, the transition may be made with a tapered weld (See sketch (c)). The land on the thicker pipe should be equal to the offset plus the land on abutting pipe.
- d. Where the nominal internal offset is more than ½ the wall thickness of the thinner pipe, and there is access to the inside of the pipe for

welding, the transition may be made with a taper cut on the inside end of the thicker pipe (See sketch (b)); or by a combination taper weld to ½ the wall thickness of the thinner pipe and a taper cut from that point (See sketch (d)).

##### **B2.2 External Diameters Unequal.**

- a. Where the external offset does not exceed ½ the wall thickness of the thinner pipe, the transition may be made by welding (See sketch (e)), provided the angle of rise of the weld surface does not exceed 30° and both bevel edges are properly fused.
- b. Where there is an external offset exceeding ½ the wall thickness of the thinner pipe, that portion of the offset over ½ the wall thickness of the thinner pipe should be tapered (See sketch (f)).

##### **B2.3 Internal and External Diameters Unequal.**

Where there are both an internal and an external offset, the joint design should be a combination of sketches (a) to (f) (See Sketch (g)). Particular attention should be paid to proper alignment under these conditions.

FIGURE B1.1  
ACCEPTABLE BUTT WELDED JOINT DESIGN FOR UNEQUAL WALL THICKNESSES

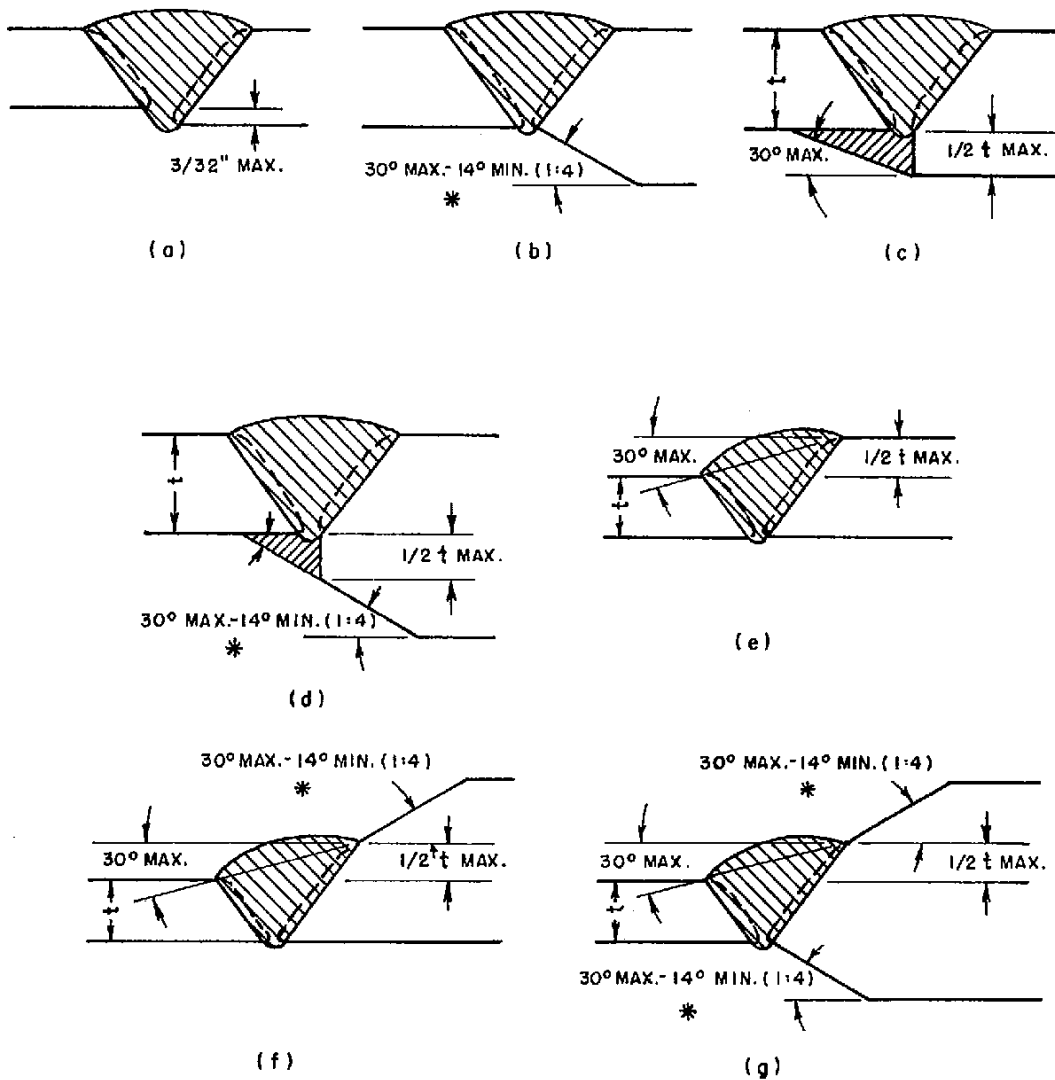

\* No min. when materials joined have equal yield strength.

t = Thickness

## APPENDIX C

### EXAMPLE PIPE, VALVES AND FITTINGS TABLES

**C.1.1 Introduction.** This Appendix demonstrates by two examples pipe, valves and fittings tables.

**C.1.2** Example C.1 shows an index for pipe, valves and fittings table.

**C.1.3** Example C.2 shows a 150 lb. ANSI pipe, valves and fittings table.

**C.2.1** The valve manufacturers and valve figure numbers have not been shown in Example C.2. One or

more valve manufacturers and figure numbers should be included in the tables.

**C.2.2** Valve equivalency tables are available from several manufacturers. Using these tables, with one manufacturer's figure number as a base, it is possible to determine the different valve manufacturers' equivalent figure numbers. By having an equivalent figure number, a valve can be quickly located in a manufacturer's catalog. This procedure allows an operator to compare manufacturing details and materials of alternate valves.

#### EXAMPLE C.1

##### EXAMPLE INDEX

##### PIPE, VALVES AND FITTINGS TABLES

Table	Service	Pressure Rating Classification
A	Non-Corrosive Hydrocarbons and Glycol	150 lb ANSI
B	Non-Corrosive Hydrocarbons and Glycol	300 lb ANSI
C	Non-Corrosive Hydrocarbons and Glycol	400 lb ANSI
D	Non-Corrosive Hydrocarbons and Glycol	600 lb ANSI
E	Non-Corrosive Hydrocarbons and Glycol	900 lb ANSI
F	Non-Corrosive Hydrocarbons and Glycol	1500 lb ANSI
G	Non-Corrosive Hydrocarbons and Glycol	2500 lb ANSI
H	Non-Corrosive Hydrocarbons	API 2000 psi
I	Non-Corrosive Hydrocarbons	API 3000 psi
J	Non-Corrosive Hydrocarbons	API 5000 psi
K	Non-Corrosive Hydrocarbons	API 10000 psi
L	Air	150 lb and 300 lb ANSI
M	Water	125 lb Cast Iron
N	Steam and Steam Condensate	150 lb, 300 lb, 400 lb and 600 lb ANSI
O	Drains and Sewers	Atmospheric
P (Spare)		
Q (Spare)		
R (Spare)		
SV	<b>Valves for Corrosive Service</b>	<b>General</b>
AA	Corrosive Hydrocarbons	150 lb ANSI
BB	Corrosive Hydrocarbons	300 lb ANSI
CC (Not Prepared)	Corrosive Hydrocarbons	400 lb ANSI
DD	Corrosive Hydrocarbons	600 lb ANSI
EE	Corrosive Hydrocarbons	900 lb ANSI
FF	Corrosive Hydrocarbons	1500 lb ANSI
GG	Corrosive Hydrocarbons	2500 lb ANSI

EXAMPLE C.2  
PIPE, VALVES, AND FITTINGS TABLE

TABLE A  
150 LB ANSI  
NON-CORROSIVE SERVICE<sup>1</sup>

TEMPERATURE RANGE.....-20 to 650°F  
MAXIMUM PRESSURE.....DEPENDS ON FLANGE RATING<sup>2</sup>  
AT SERVICE TEMPERATURE

Size Ranges	General Specifications	Platform Service
<b>Pipe</b>	Grade Depends on Service	ASTM A106, Grade B, Seamless <sup>3</sup>
¾" and smaller nipples	threaded and coupled	Schedule 160 or XXH
1½" and smaller pipe	threaded and coupled	Schedule 80 min
2" through 3" pipe	beveled end	Schedule 80 min
4" and larger pipe	beveled end	See Table 2.4
<b>Valves (Do not use for temperatures above maximum indicated.)</b>		
<b>Ball</b>		
½" and smaller	1500 lb CWP AISI 316 SS screwed, regular port, wrench operated, Teflon seat	Manufacturers Figure No. _____ (300°F)
¾" through 1½"	1500 lb CWP, CS, screwed, regular port, wrench operated, Teflon seat	Manufacturers Figure No. _____ or Figure No. _____ (450°F)
2" through 8"	150 lb ANSI CS RF flanged, regular port, lever or hand wheel operated, trunnion mounted	Etc.
10" and larger	150 lb ANSI CS RF flanged, regular port, gear operated, trunnion mounted	Etc.
<b>Gate</b>		
½" and smaller	2000 lb CWP, screwed, bolted bonnet, AISI 316 SS	Etc.
¾" through 1½"	2000 lb CWP, screwed, bolted bonnet, forged steel	Etc.
2" through 12"	150 lb ANSI CS RF flanged, standard trim, handwheel or lever operated	Etc.
<b>Globe</b>		
1½" and smaller (Hydrocarbons)	2000 lb CWP CS screwed	Etc.
1½" and smaller (Glycol)	2000 lb CWP CS socketweld	Etc.
2" and larger	150 lb ANSI CS RF flanged, handwheel operated	Etc.
<b>Check</b>		
1½" and smaller	600 lb ANSI FS screwed, bolted bonnet <sup>4</sup> , standard trim	Etc.
2" and larger	150 lb ANSI CS RF flanged, bolted bonnet <sup>4</sup> , swing check, standard trim	Etc.
Reciprocating Compressor Discharge	300 lb ANSI CS RF flanged, piston check, bolted bonnet <sup>4</sup>	Etc.
Lubricated Plug 1½" through 6"	150 lb ANSI CS RF Flanged, Bolted Bonnet (See Section 3.2.c)	Etc.
Non-Lubricated Plug 1½" through 6"	150 lb ANSI CS RF Flanged, Bolted Bonnet (See Section 3.2.c)	Etc.



EXAMPLE C.2  
(Continued)

TEMPERATURE RANGE.....-20 to 650°F  
 MAXIMUM PRESSURE.....DEPENDS ON FLANGE RATING<sup>2</sup>  
 AT SERVICE TEMPERATURE

Size Ranges	General Specifications	Platform Service
<b>Compressor Laterals</b>		
	Use ball valves	
<b>Needle</b> ¼" through ½"	6000 lb CWP, bar stock screwed, AISI 316 SS	Etc.
<b>Fittings<sup>5</sup></b>		
<b>Ells and Tees</b> ¾" and smaller	6000 lb FS screwed	ASTM A105
1" through 1½"	3000 lb FS screwed	ASTM A105
2" and larger	Butt weld, seamless, wall to match pipe	ASTM A234, Grade WPB
<b>Unions</b>		
¾" and smaller	6000 lb FS screwed, ground joint, steel to steel seat	ASTM A105
1" through 1½"	3000 lb FS screwed, ground joint, steel to steel seat	ASTM A105
2" and larger	Use flanges	
<b>Couplings</b>		
1" and smaller	6000 lb FS screwed	ASTM A105
1½"	3000 lb FS screwed	ASTM A105
<b>Plugs</b>		
1½" and smaller	Solid bar stock, forged steel	ASTM A105
2" and larger	X-Strong seamless, weld cap	ASTM A234, Grade WPB
<b>Screwed Reducers</b>		
¾" and smaller	Sch. 160 seamless	ASTM A105
1" through 1½"	Sch. 80 seamless	ASTM A105
<b>Flanges<sup>5</sup></b>		
1½" and smaller	150 lb ANSI FS RF screwed	ASTM A105
2" and larger	150 lb ANSI FS RF weld neck, bored to pipe schedule	ASTM A105
<b>Bolting</b>		
<b>Studs</b>	Class 2 fit, threaded over length	ASTM A193, Grade B7 <sup>4</sup>
<b>Nuts</b>	Class 2 fit, heavy hexagon, semi-finish	ASTM A194, Grade 2H <sup>4</sup>
<b>Gaskets</b>	Spiral wound asbestos	Spiral Wound Mfg. Type _____ or Mfg. No. _____ w/AISI 304 SS windings
<b>Thread Lubricant</b>	Conform to API Bulletin 5A2	Mfg. No. _____

NOTES:

1. For glycol service, all valves and fittings shall be flanged or socketweld.
2. API 5L, Grade B, Seamless may be substituted if ASTM A106, Grade B, Seamless is not available.
3. Studs and nuts shall be hot-dip galvanized in accordance with ASTM A153.
4. Fittings and flanges that do not require normalizing in accordance with ASTM A105, due to size or pressure rating, shall be normalized when used for service temperatures from -20°F to 60°F. Fittings and flanges shall be marked HT, N, \* or with some other appropriate marking to designate normalizing.

## APPENDIX D

### LIST OF EQUATIONS

Equation Number	Description	Page
2.1	Flow Velocity in Liquids Lines .....	15
2.2	Pressure Drop in Liquid Lines .....	15
2.3	Reynold's Number .....	15
2.4	Available Net Positive Suction Head (NPSH <sub>a</sub> ) .....	20
2.5	Acceleration Head .....	20
2.6	General Pressure Drop Equation .....	21
2.7	General Pressure Drop Equation .....	21
2.8	General Pressure Drop Equation .....	21
2.9	General Pressure Drop Equation .....	21
2.10	Weymouth Equation .....	22
2.11	Panhandle Equation .....	22
2.12	Spitzglass Equation .....	22
2.13	Gas Velocity Equation .....	22
2.14	Empirical Equation .....	23
2.15	Density of a Gas/Liquid Mixture .....	23
2.16	Minimum Pipe Cross-Sectional Area Required to Avoid Fluid Erosion .....	23
2.17	Pressure Drop in Two-Phase Lines .....	23
2.18	Liquid Plus Vapor Rate in a Two-Phase Line (Weight Flow) .....	23
2.19	Minimum Pipe Wall Thickness .....	25
2.20	Stress Analysis Criteria for a Two-Anchor System .....	25
2.21	Therman Expansion of Piping .....	25
3.1	Pressure Drop Across a Valve in Liquid Service .....	30
3.2	Pressure Drop Across a Valve in Gas Service .....	30

---

---

**APPENDIX E**  
**LIST OF FIGURES**

Figure Number	Title	Page
1.1	Example Process System Denoting Flange and Valve Pressure Rating Changes .....	12
2.1	Velocity in Liquid Lines .....	17
2.2	Pressure Drop in Liquid Lines .....	18
2.3	Friction Factor Chart (Modified Moody Diagram) .....	19
2.5	Erosional Velocity Chart .....	24
5.1.A	Example Schematic Drawing of Piping and Accessories for Flowlines and Manifolds That Are Not Rated for Wellhead Pressure .....	36
5.1.B	Example Schematic Drawing of Piping and Accessories for Flowlines and Manifolds That Are Rated for Wellhead Pressure .....	37
5.2	Example Schematic Drawing of Three-Phase Process Vessel Showing Various Accessories .....	39
B1.1	Acceptable Butt Welded Joint Design for Unequal Wall Thicknesses .....	53
C.1	Example Index for Pipe, Valves and Fittings Tables .....	54
C.2	Example Pipe, Valves and Fittings Table .....	55

**APPENDIX F**  
**LIST OF TABLES**

<b>Table Number</b>	<b>Title and/or Description</b>	<b>Page</b>
1.1	Qualitative Guidelines for Weight Loss Corrosion of Steel .....	13
2.1	Typical Surge Factors .....	15
2.2	Equivalent Length of 100 Percent Opening Valves and Fittings in Feet .....	16
2.3	Typical Flow Velocities (For reciprocating and centrifugal pump piping) .....	21
2.5	Maximum Allowable Working Pressures — Platform Piping (For various sizes and wall thickness of ASTM A106, Grade B, seamless pipe) .....	27
4.1	Branch Connection Schedule — Welded Piping .....	33
6.1	Typical Hot Insulation Thickness .....	44
6.2	Typical Cold Insulation Thickness .....	44
6.8	Typical Insulation for Personnel Protection (Applicable hot surface temperature ranges).....	44
7.1	Minimum Extent of Radiographic Weld Examination (For carbon steel material) .....	45

**Order No. 811-07185**

**Additional copies available from**  
**AMERICAN PETROLEUM INSTITUTE**  
Publications and Distribution Section  
1220 L Street, NW  
Washington, DC 20005  
(202) 682-8375

